

# 酒匂川流域下水道台帳

## 施設平面縦断面図

(図面番号 9)

幹線名 左岸幹線

小田原市 飯泉

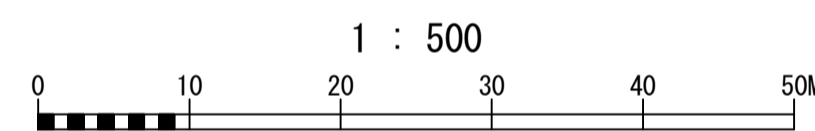
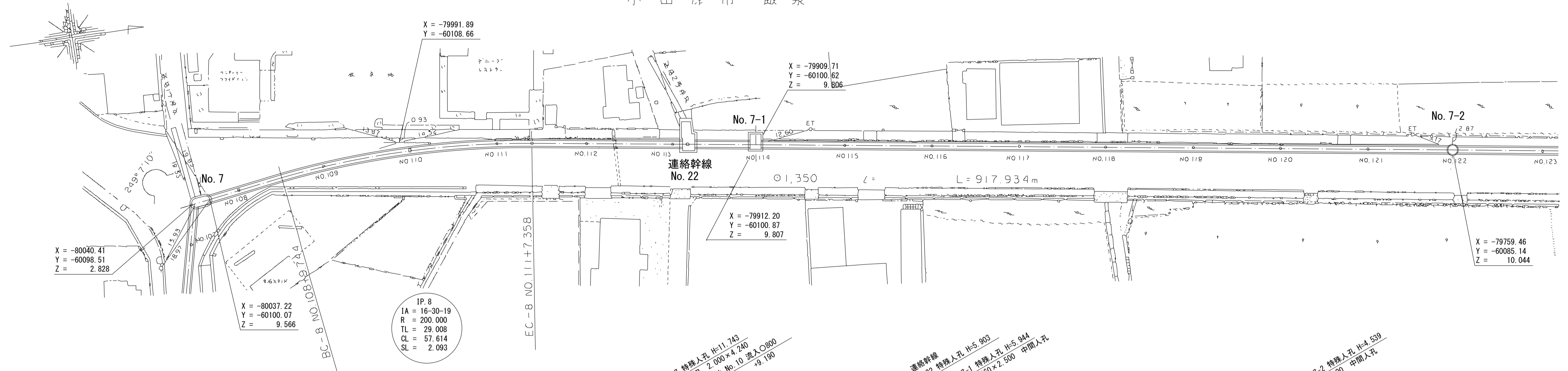

管渠構造図 S=1:50

E

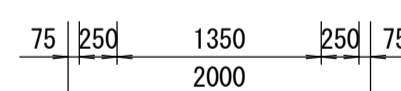
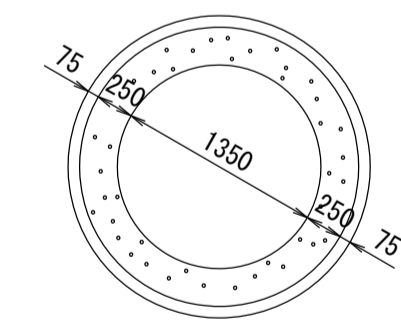

鋼製セグメント t=75mm  
二次覆工 t=250mm

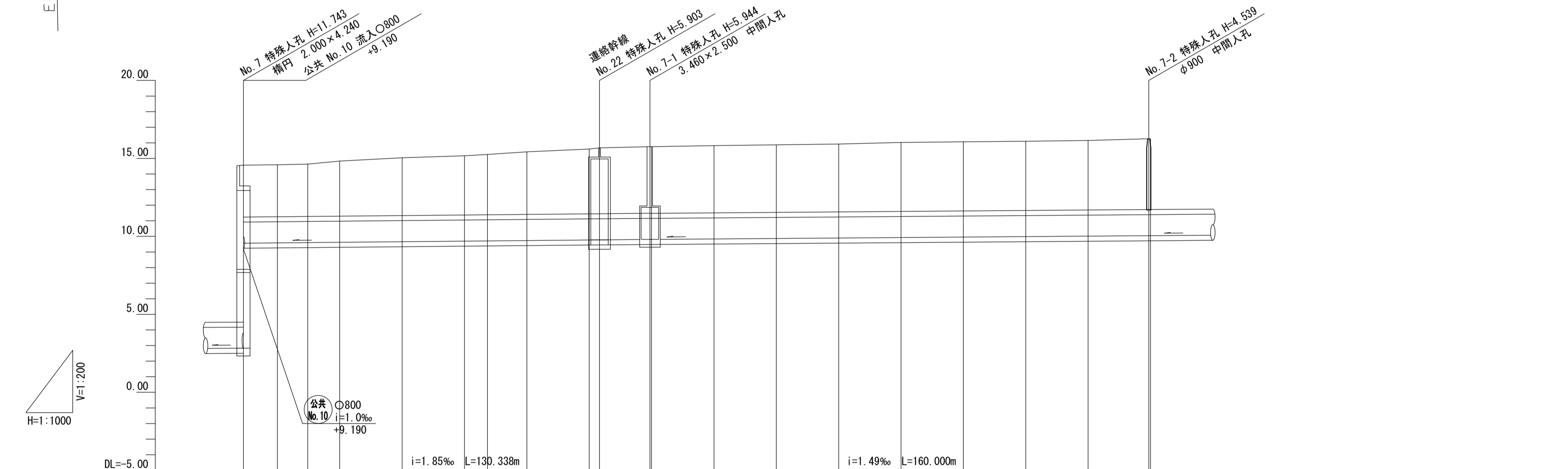

|      |                             |                                 |                    |                     |                                 |                     |                    |                     |                     |                     |                    |                     |                     |                     |                     |                     |                     |                     |                     |                    |
|------|-----------------------------|---------------------------------|--------------------|---------------------|---------------------------------|---------------------|--------------------|---------------------|---------------------|---------------------|--------------------|---------------------|---------------------|---------------------|---------------------|---------------------|---------------------|---------------------|---------------------|--------------------|
| 施工区  | 昭和58年度 第6-1工区               |                                 |                    |                     |                                 |                     |                    |                     |                     |                     |                    |                     |                     |                     |                     |                     |                     |                     |                     |                    |
| 占用区間 | 国道255号線                     |                                 |                    |                     |                                 |                     |                    |                     |                     |                     |                    |                     |                     |                     |                     |                     |                     |                     |                     |                    |
| 管渠築造 | E                           |                                 |                    |                     |                                 |                     |                    |                     |                     |                     |                    |                     |                     |                     |                     |                     |                     |                     |                     |                    |
| 土被り  | 10.066<br>3.330             |                                 |                    |                     |                                 | 4.228               | 4.269<br>4.267     |                     |                     |                     |                    | 4.539               |                     |                     |                     |                     |                     |                     |                     |                    |
| 地盤高  | 14.571                      | 14.589                          | 14.633             | 14.827              | 15.038                          | 15.172              | 15.254             | 15.420              | 15.600<br>15.680    | 15.751<br>15.756    | 15.824             | 15.869              | 15.919              | 16.023              | 16.063              | 16.089              | 16.151              | 16.258<br>16.245    |                     |                    |
| 管底高  | 2.828<br>9.566              |                                 |                    |                     |                                 |                     |                    |                     | 9.777               | 9.807<br>9.806      |                    |                     |                     |                     |                     |                     |                     | 10.044              |                     |                    |
| 追加距離 | 0.000<br>-2149.122          | 10.878<br>-2160.000             | 9.744<br>-2169.744 | 10.256<br>-2180.000 | 20.000<br>-2200.000             | 20.000<br>-2220.000 | 7.358<br>-2227.358 | 12.642<br>-2240.000 | 20.000<br>-2260.000 | 16.162<br>-2279.460 | 0.540<br>-2280.000 | 20.000<br>-2300.000 | 20.000<br>-2320.000 | 20.000<br>-2340.000 | 20.000<br>-2360.000 | 20.000<br>-2380.000 | 20.000<br>-2400.000 | 20.000<br>-2420.000 | 19.460<br>-2439.460 | 0.540<br>-2440.000 |
| 区間距離 | 0.000                       | 10.878                          | 9.744              | 10.256              | 20.000                          | 20.000              | 7.358              | 12.642              | 20.000              | 16.162              | 0.540              | 20.000              | 20.000              | 20.000              | 20.000              | 20.000              | 20.000              | 20.000              | 19.460              | 0.540              |
| 測点   | No.107<br>+9.122<br>(No.12) | No.108<br>EC-8 No.108<br>+9.744 | No.109             | No.110              | No.111<br>EC-8 No.111<br>+7.358 | No.112              | No.113<br>+3.298   | No.114<br>+19.460   | No.115              | No.116              | No.117             | No.118              | No.119              | No.120              | No.121              | No.122<br>+19.460   |                     |                     |                     |                    |

# 酒匂川流域下水道台帳

## 施設平面縦断図

(図面番号 10)

幹線名 左岸幹線

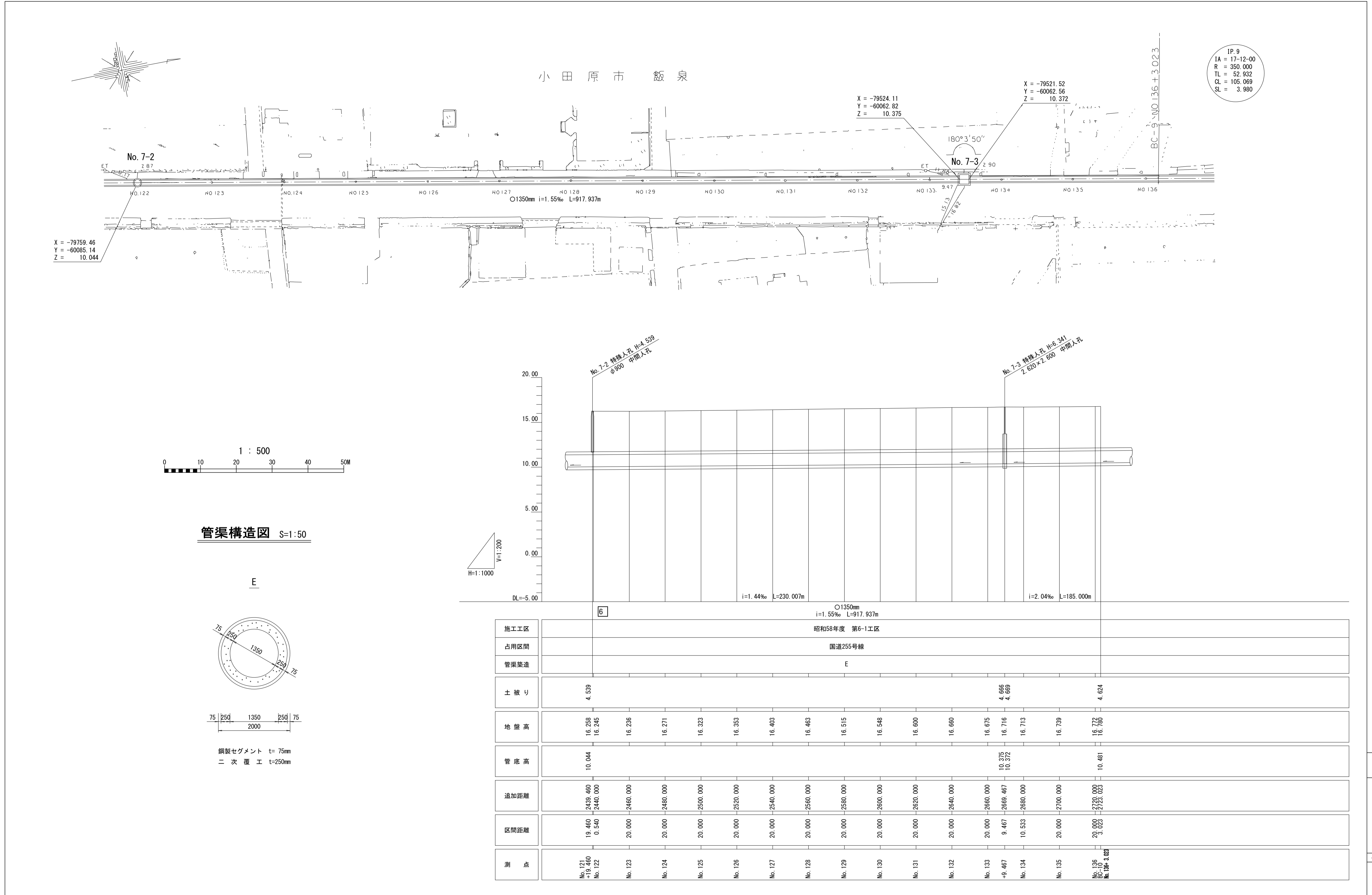

管渠構造図 S=1:50

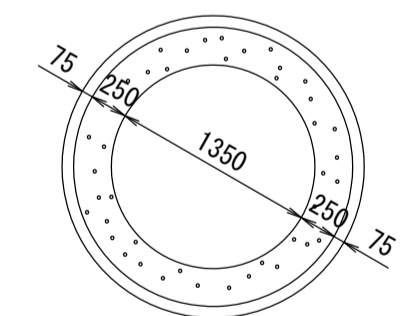

鋼製セグメント t=75mm  
二次覆工 t=250mm

|      |                            |          |          |          |          |          |          |          |          |          |          |          |          |                  |          |          |                        |          |
|------|----------------------------|----------|----------|----------|----------|----------|----------|----------|----------|----------|----------|----------|----------|------------------|----------|----------|------------------------|----------|
| 施工区  | 昭和58年度 第6-1工区              |          |          |          |          |          |          |          |          |          |          |          |          |                  |          |          |                        |          |
| 占用区間 | 国道255号線                    |          |          |          |          |          |          |          |          |          |          |          |          |                  |          |          |                        |          |
| 管渠築造 | E                          |          |          |          |          |          |          |          |          |          |          |          |          |                  |          |          |                        |          |
| 土被り  | 4.539                      |          |          |          |          |          |          |          |          |          |          |          | 4.666    | 4.669            |          | 4.624    |                        |          |
| 地盤高  | 16.259                     | 16.245   | 16.236   | 16.271   | 16.323   | 16.353   | 16.403   | 16.463   | 16.515   | 16.548   | 16.600   | 16.660   | 16.675   | 16.716           | 16.713   | 16.739   | 16.772                 | 16.780   |
| 管底高  | 10.044                     |          |          |          |          |          |          |          |          |          |          |          | 10.375   | 10.372           |          |          | 10.461                 |          |
| 追加距離 | 2439.460                   | 2440.000 | 2460.000 | 2480.000 | 2500.000 | 2520.000 | 2540.000 | 2560.000 | 2580.000 | 2600.000 | 2620.000 | 2640.000 | 2660.000 | 2669.467         | 2680.000 | 2700.000 | 2720.000               | 2723.023 |
| 区間距離 | 19.460                     | 0.540    | 20.000   | 20.000   | 20.000   | 20.000   | 20.000   | 20.000   | 20.000   | 20.000   | 20.000   | 20.000   | 20.000   | 9.467            | 10.533   | 20.000   | 20.000                 | 3.023    |
| 測点   | No.121<br>No.120<br>No.122 |          | No.123   | No.124   | No.125   | No.126   | No.127   | No.128   | No.129   | No.130   | No.131   | No.132   | No.133   | +9.467<br>No.134 | No.135   |          | No.136<br>No.134+3.023 |          |

# 酒匂川流域下水道台帳

## 施設平面縦断図

(図面番号 11)

幹線名 左岸幹線

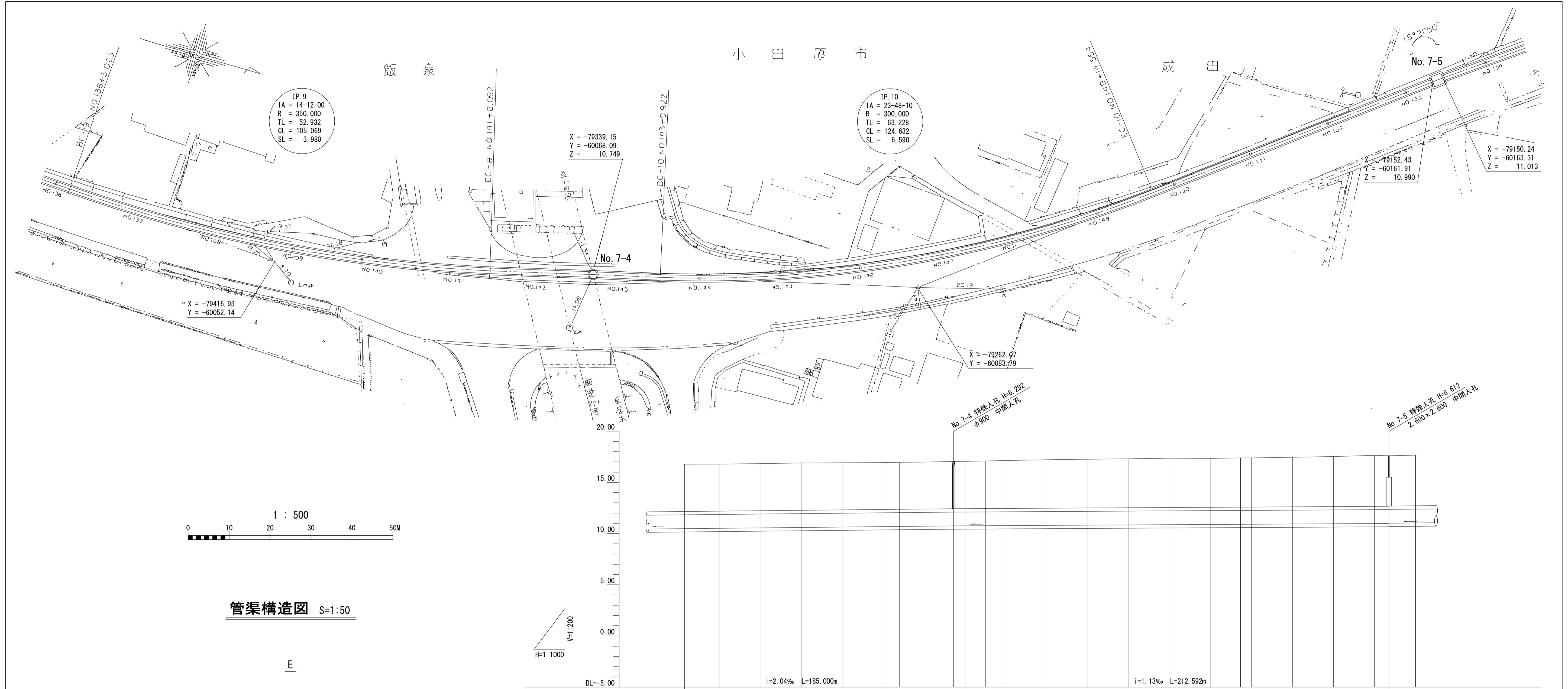

管渠構造図 S=1:50

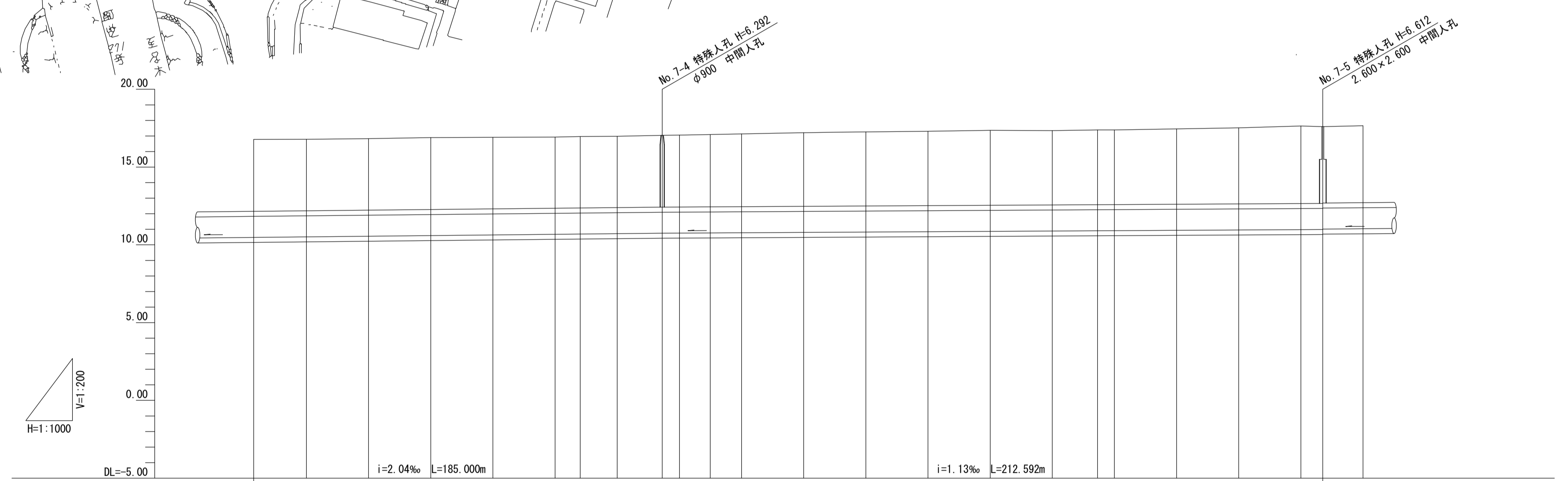
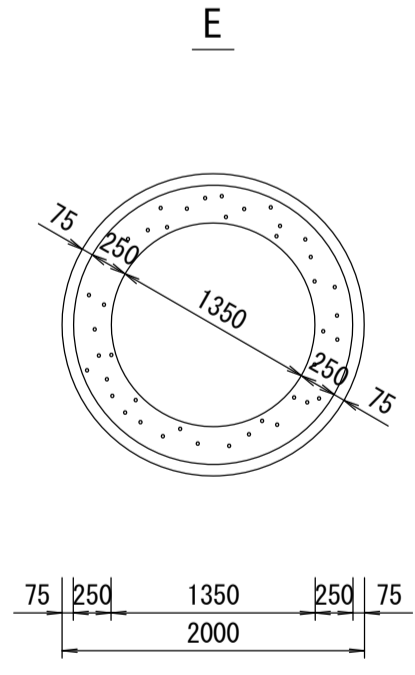

|      |                            |           |           |           |           |           |                            |           |                    |                            |           |           |           |           |           |           |                             |           |           |           |           |                   |           |           |  |
|------|----------------------------|-----------|-----------|-----------|-----------|-----------|----------------------------|-----------|--------------------|----------------------------|-----------|-----------|-----------|-----------|-----------|-----------|-----------------------------|-----------|-----------|-----------|-----------|-------------------|-----------|-----------|--|
| 施工工区 | 昭和58年度 第6-1工区              |           |           |           |           |           |                            |           |                    |                            |           |           |           |           |           |           |                             |           |           |           |           |                   |           |           |  |
| 占用区間 | 国道255号線                    |           |           |           |           |           |                            |           |                    |                            |           |           |           |           |           |           |                             |           |           |           |           |                   |           |           |  |
| 管渠築造 | E                          |           |           |           |           |           |                            |           |                    |                            |           |           |           |           |           |           |                             |           |           |           |           |                   |           |           |  |
| 土被り  | 4.624                      |           |           |           |           |           | 4.617                      |           |                    |                            |           |           |           |           | 4.937     | 4.914     |                             |           |           |           |           |                   |           |           |  |
| 地盤高  | 16.780                     | 16.789    | 16.830    | 16.898    | 16.914    | 16.933    | 16.961                     | 16.983    | 17.041             | 17.058                     | 17.090    | 17.129    | 17.206    | 17.256    | 17.304    | 17.361    | 17.347                      | 17.385    | 17.387    | 17.454    | 17.524    | 17.641            | 17.602    | 17.662    |  |
| 管底高  | 10.481                     |           |           |           |           |           |                            |           | 10.749             |                            |           |           |           |           |           |           |                             |           |           |           |           |                   | 10.990    | 11.013    |  |
| 追加距離 | -2723.023                  | -2740.000 | -2760.000 | -2780.000 | -2800.000 | -2820.000 | -2828.092                  | -2840.000 | -2854.467          | -2860.000                  | -2869.922 | -2880.000 | -2900.000 | -2920.000 | -2940.000 | -2960.000 | -2980.000                   | -2994.554 | -3000.000 | -3020.000 | -3040.000 | -3060.000         | -3067.059 | -3080.000 |  |
| 区間距離 | 3.023                      | 16.977    | 20.000    | 20.000    | 20.000    | 20.000    | 8.092                      | 11.908    | 14.467             | 5.533                      | 9.922     | 10.078    | 20.000    | 20.000    | 20.000    | 20.000    | 20.000                      | 14.554    | 5.446     | 20.000    | 20.000    | 20.000            | 7.059     | 12.941    |  |
| 測点   | BC-10<br>No. 136<br>+3.023 | No. 137   | No. 138   | No. 139   | No. 140   | No. 141   | EC-10<br>No. 141<br>+8.092 | No. 142   | +14.467<br>No. 143 | BC-11<br>No. 143<br>+8.922 | No. 144   | No. 145   | No. 146   | No. 147   | No. 148   | No. 149   | EC-11<br>No. 149<br>+14.554 | No. 150   | No. 151   | No. 152   | No. 153   | +7.059<br>No. 154 | No. 154   |           |  |

# 酒匂川流域下水道台帳

## 施設平面縦断図

(図面番号 12)

幹線名 左岸幹線

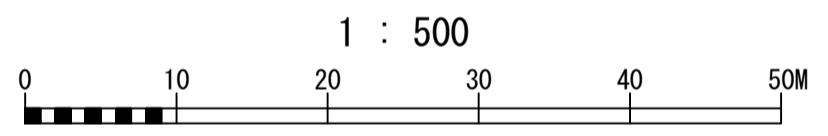
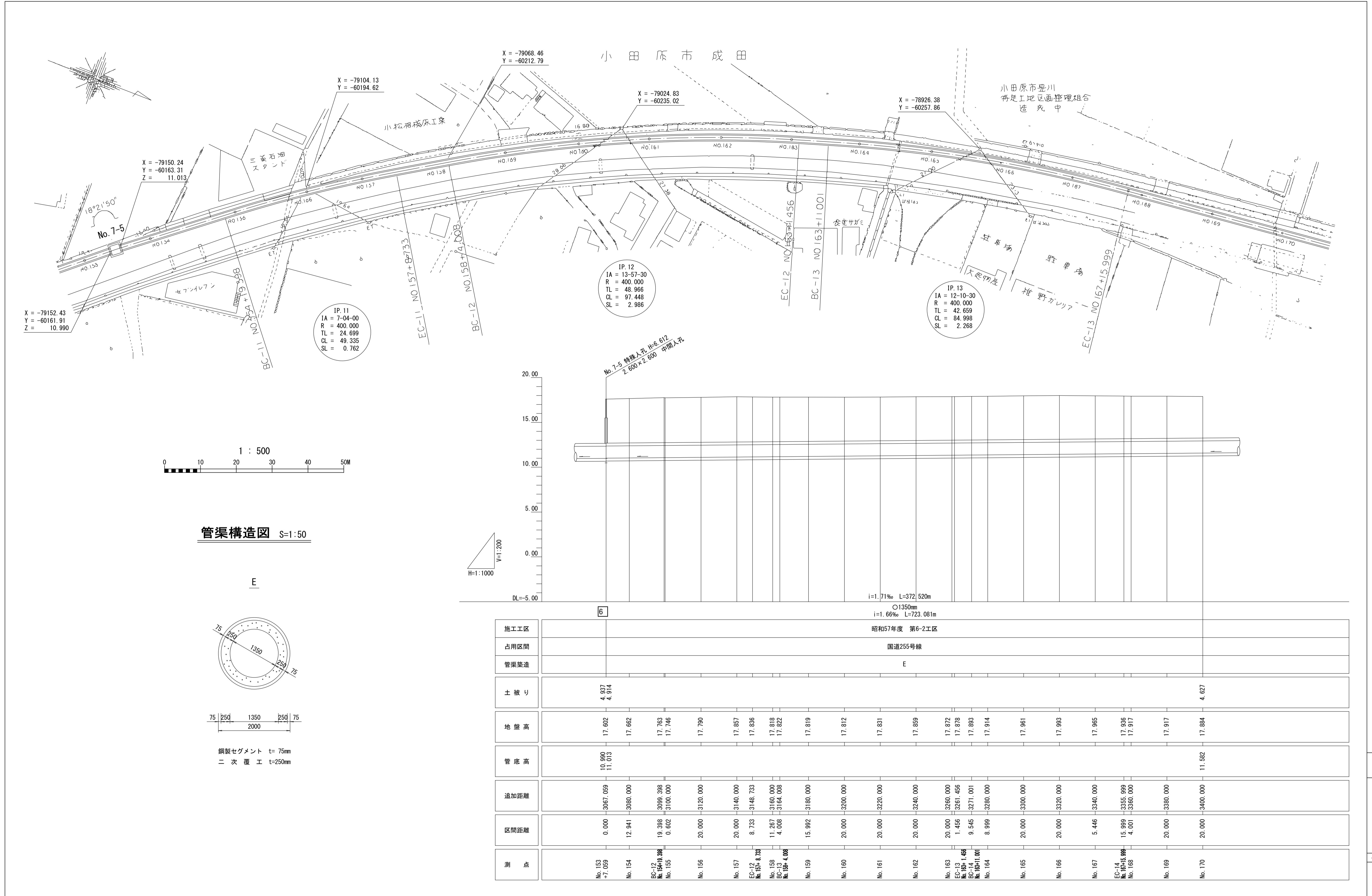

管渠構造図 S=1:50

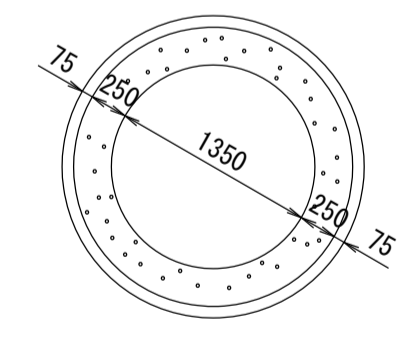

鋼製セグメント t=75mm  
二次覆工 t=250mm

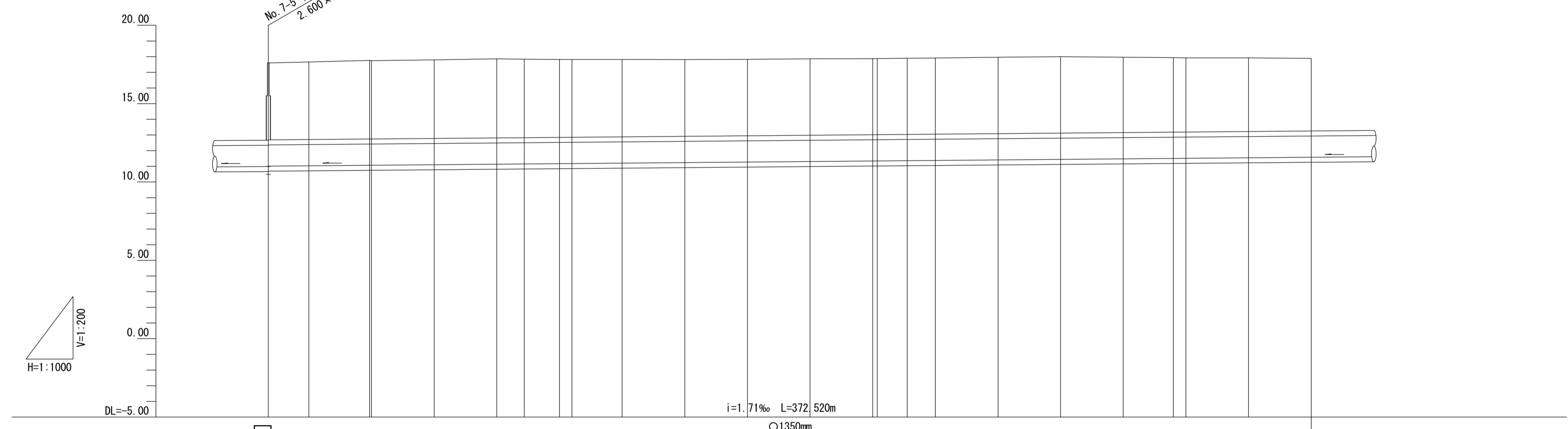

| 施工区  | 昭和57年度 第6-2工区     |           |                                   |                        |           |                        |                        |                        |           |           |           |  |                        |           |           |           |                                   |           |                        |                 |           |        |        |        |
|------|-------------------|-----------|-----------------------------------|------------------------|-----------|------------------------|------------------------|------------------------|-----------|-----------|-----------|--|------------------------|-----------|-----------|-----------|-----------------------------------|-----------|------------------------|-----------------|-----------|--------|--------|--------|
| 占用区間 | 国道255号線           |           |                                   |                        |           |                        |                        |                        |           |           |           |  |                        |           |           |           |                                   |           |                        |                 |           |        |        |        |
| 管渠築造 | E                 |           |                                   |                        |           |                        |                        |                        |           |           |           |  |                        |           |           |           |                                   |           |                        |                 |           |        |        |        |
| 土被り  | 4,937<br>4,914    |           |                                   |                        |           |                        |                        |                        |           |           |           |  |                        |           |           |           |                                   | 4,627     |                        |                 |           |        |        |        |
| 地盤高  | 17.602            | 17.682    | 17.763                            | 17.746                 | 17.790    | 17.857                 | 17.836                 | 17.818                 | 17.822    | 17.819    | 17.812    | 17.831   | 17.859                 | 17.872    | 17.878    | 17.893    | 17.914                            | 17.961    | 17.993                 | 17.965          | 17.936    | 17.917 | 17.884 |        |
| 管底高  | 10.990<br>11.013  |           |                                   |                        |           |                        |                        |                        |           |           |           |  |                        |           |           |           |                                   |           |                        |                 |           |        |        | 11.592 |
| 追加距離 | 0.000             | -3067.059 | -3080.000                         | -3099.398<br>-3100.000 | -3120.000 | -3140.000              | -3148.733              | -3160.000<br>-3164.008 | -3180.000 | -3200.000 | -3220.000 | -3240.000  | -3260.000<br>-3261.456 | -3271.001 | -3280.000 | -3300.000 | -3320.000                         | -3340.000 | -3355.999<br>-3360.000 | -3380.000       | -3400.000 |        |        |        |
| 区間距離 | 0.000             | 12.941    | 19.398<br>0.602                   | 20.000                 | 20.000    | 8.733                  | 4.008                  | 15.992                 | 20.000    | 20.000    | 20.000    | 20.000   | 20.000                 | 1.456     | 9.545     | 8.999     | 20.000                            | 20.000    | 5.446                  | 15.999<br>4.001 | 20.000    | 20.000 |        |        |
| 測点   | No. 153<br>+7.059 | No. 154   | BC-12<br>No. 154+3.388<br>No. 155 | No. 156                | No. 157   | EC-12<br>No. 157+8.733 | BC-13<br>No. 158+4.008 | No. 159                | No. 160   | No. 161   | No. 162   | EC-13<br>No. 163+1.456<br>BC-14<br>No. 163+1.001 | No. 164                | No. 165   | No. 166   | No. 167   | EC-14<br>No. 167+5.999<br>No. 168 | No. 169   | No. 170                |                 |           |        |        |        |

# 酒匂川流域下水道台帳

## 施設平面縦断図

(図面番号 13)

幹線名 左岸幹線

小田原市 成田

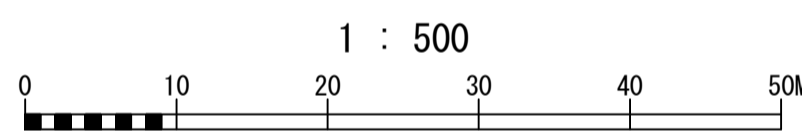
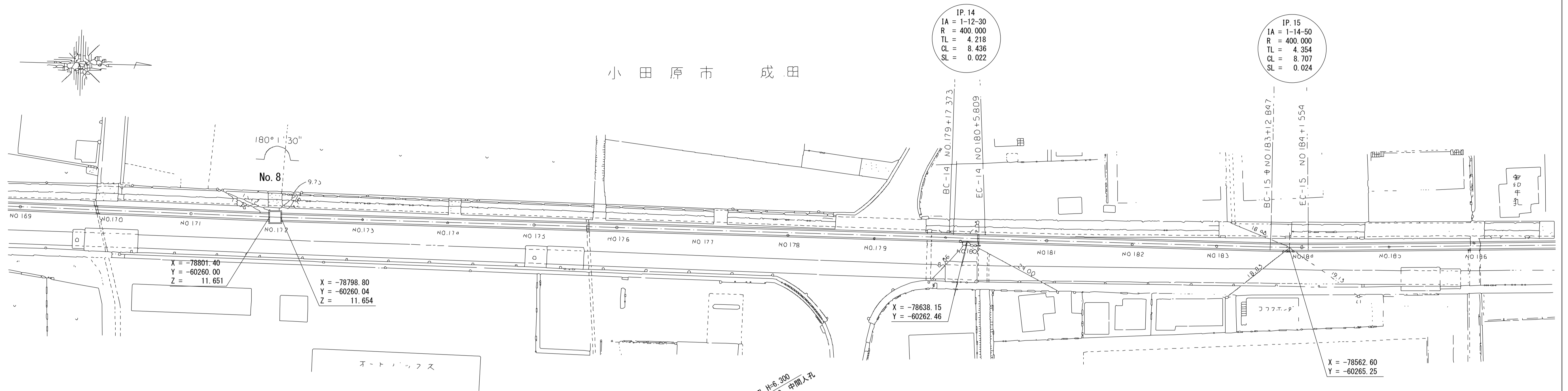

管渠構造図 S=1:50

E

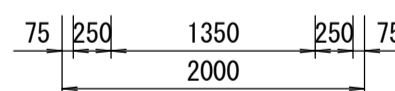
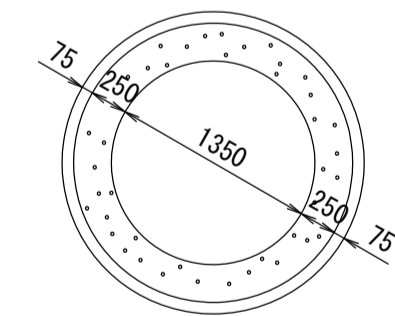

鋼製セグメント t=75mm  
二次覆工 t=250mm

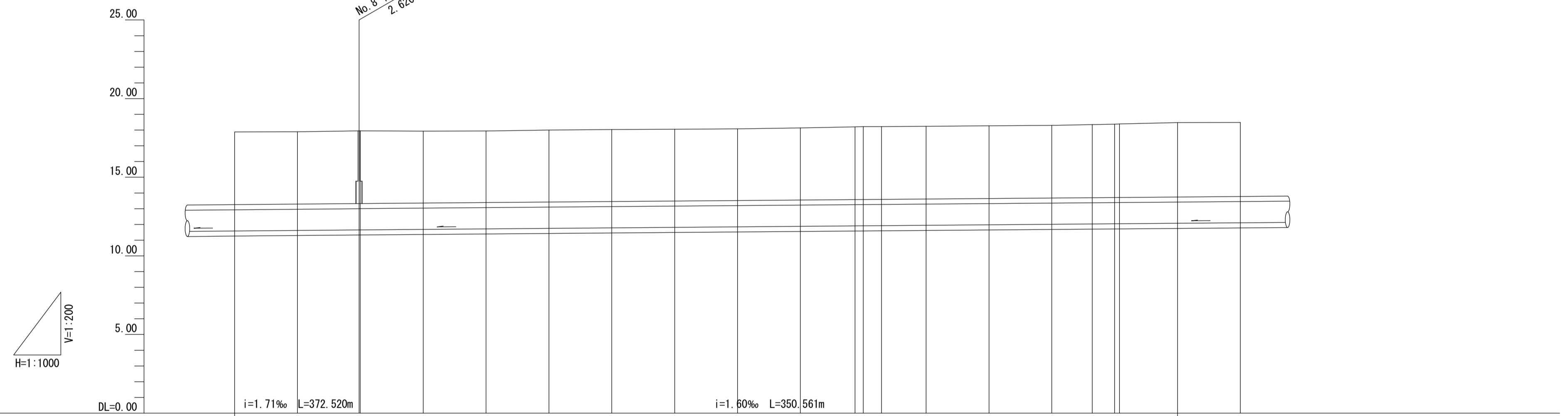

|      |               |           |                   |        |           |           |           |           |           |           |                       |                 |                       |          |          |           |                       |                 |                       |           |           |           |           |
|------|---------------|-----------|-------------------|--------|-----------|-----------|-----------|-----------|-----------|-----------|-----------------------|-----------------|-----------------------|----------|----------|-----------|-----------------------|-----------------|-----------------------|-----------|-----------|-----------|-----------|
| 施工区  | 昭和57年度 第6-2工区 |           |                   |        |           |           |           |           |           |           |                       |                 |                       |          |          |           |                       |                 |                       |           |           |           |           |
| 占用区間 | 国道255号線       |           |                   |        |           |           |           |           |           |           |                       |                 |                       |          |          |           |                       |                 |                       |           |           |           |           |
| 管渠築造 | E             |           |                   |        |           |           |           |           |           |           |                       |                 |                       |          |          |           |                       |                 |                       |           |           |           |           |
| 土被り  | 4.627         |           | 4.625             | 4.622  |           |           |           |           |           |           |                       |                 |                       |          |          | 4.730     |                       |                 |                       |           |           |           |           |
| 地盤高  | 17.884        | 17.892    | 17.951            | 17.948 | 17.933    | 17.940    | 18.001    | 18.036    | 18.048    | 18.077    | 18.140                | 18.208          | 18.217                | 18.222   | 18.239   | 18.274    | 18.297                | 18.349          | 18.371                | 18.387    | 18.476    | 18.484    |           |
| 管底高  | 11.592        |           | 11.651            | 11.654 |           |           |           |           |           |           |                       |                 |                       |          |          |           |                       |                 |                       |           | 12.071    | 12.103    |           |
| 追加距離 | 0.000         | -3400.000 | -3439.579         | 0.421  | -3440.000 | -3460.000 | -3480.000 | -3500.000 | -3520.000 | -3540.000 | -3560.000             | -3580.000       | 3597.373              | 3600.000 | 3605.809 | -3620.000 | -3640.000             | -3660.000       | -3672.847             | -3680.000 | -3681.554 | -3700.000 | -3720.000 |
| 区間距離 |               | 20.000    | 19.579            | 0.421  | 20.000    | 20.000    | 20.000    | 20.000    | 20.000    | 20.000    | 20.000                | 20.000          | 17.373                | 2.627    | 5.809    | 14.191    | 20.000                | 20.000          | 12.847                | 7.153     | 1.554     | 18.446    | 20.000    |
| 測点   | No.170        | No.171    | +19.579<br>No.172 | No.173 | No.174    | No.175    | No.176    | No.177    | No.178    | No.179    | BC-15<br>No.179+7.373 | EC-14<br>No.180 | EC-15<br>No.180+5.809 | No.181   | No.182   | No.183    | BC-15<br>No.183+2.847 | EC-15<br>No.184 | EC-15<br>No.184+1.554 | No.185    | No.186    |           |           |

# 酒匂川流域下水道台帳

## 施設平面縦断面図

(図面番号 14)

幹線名 左岸幹線

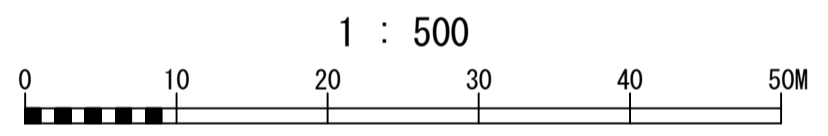
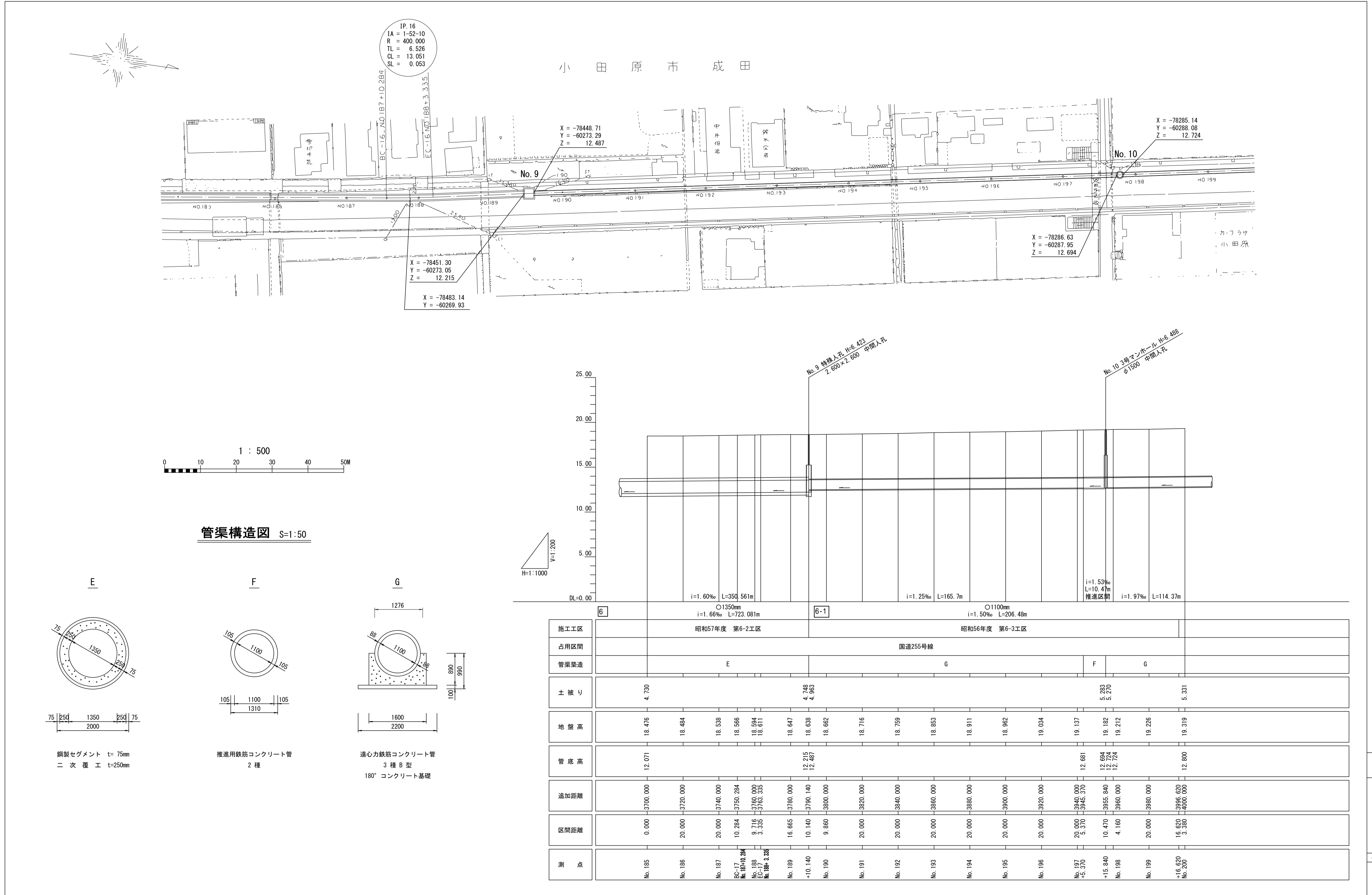

管渠構造図 S=1:50

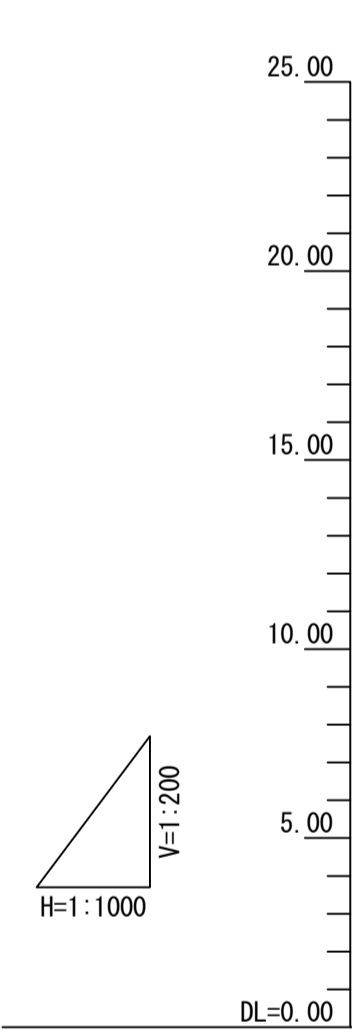
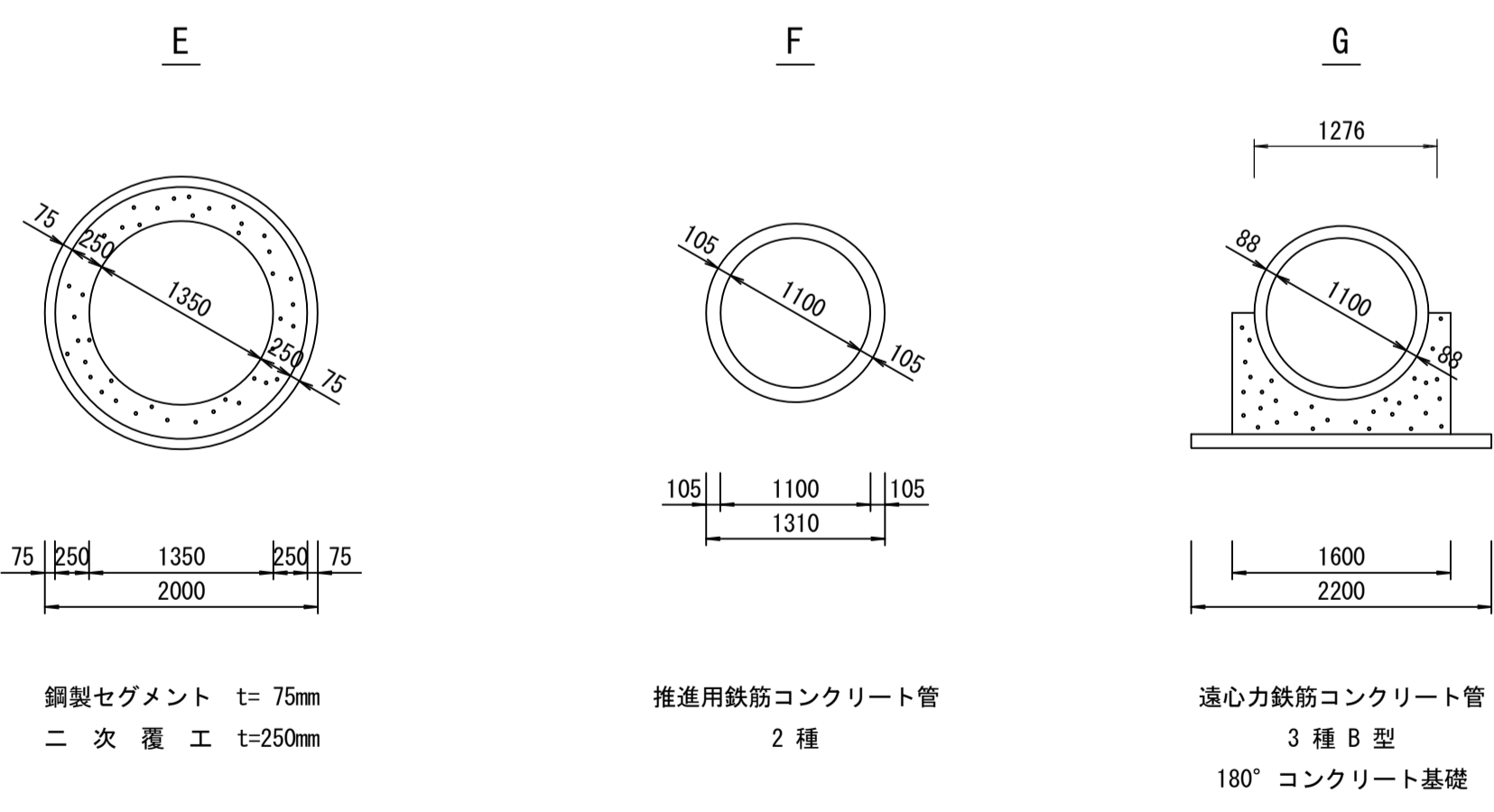

| 測点   | 昭和57年度 第6-2工区                 |           |           |                       |           |                       |           |           |           |           | 昭和56年度 第6-3工区                |           |           |           |           |                  |                   |           |                   |           |
|------|-------------------------------|-----------|-----------|-----------------------|-----------|-----------------------|-----------|-----------|-----------|-----------|------------------------------|-----------|-----------|-----------|-----------|------------------|-------------------|-----------|-------------------|-----------|
|      | No.185                        | No.186    | No.187    | BC-17<br>No.187+0.284 | No.188    | EC-18<br>No.188+3.335 | No.189    | +10.140   | No.190    | No.191    | No.192                       | No.193    | No.194    | No.195    | No.196    | No.197<br>+3.370 | +15.840<br>No.198 | No.199    | +16.620<br>No.200 |           |
| 施工工区 | 昭和57年度 第6-2工区                 |           |           |                       |           |                       |           |           |           |           | 昭和56年度 第6-3工区                |           |           |           |           |                  |                   |           |                   |           |
| 占用区間 | 国道255号線                       |           |           |                       |           |                       |           |           |           |           |                              |           |           |           |           |                  |                   |           |                   |           |
| 管渠築造 | E                             |           |           |                       |           |                       |           |           |           |           | G                            |           |           |           |           |                  |                   |           |                   |           |
| 土被り  | 4.730                         |           |           |                       |           |                       |           |           |           |           | 4.748<br>4.963               |           |           |           |           |                  |                   |           |                   |           |
| 地盤高  | 18.476                        | 18.484    | 18.538    | 18.566                | 18.584    | 18.611                | 18.647    | 18.638    | 18.662    | 18.716    | 18.759                       | 18.853    | 18.911    | 18.962    | 19.034    | 19.137           | 19.182            | 19.212    | 19.226            | 19.319    |
| 管底高  | 12.071                        |           |           |                       |           |                       | 12.215    | 12.487    |           |           |                              |           |           |           |           | 12.681           | 12.694            | 12.724    |                   | 12.800    |
| 追加距離 | 0.000                         | -3700.000 | -3720.000 | -3740.000             | -3750.284 | -3760.000             | -3763.335 | -3780.000 | -3790.140 | -3800.000 | -3820.000                    | -3840.000 | -3860.000 | -3880.000 | -3900.000 | -3920.000        | -3940.000         | -3945.370 | -3955.840         | -3960.000 |
| 区間距離 |                               | 20.000    | 20.000    | 10.284                | 9.716     | 3.335                 | 16.665    | 10.140    | 9.860     | 20.000    | 20.000                       | 20.000    | 20.000    | 20.000    | 20.000    | 20.000           | 3.370             | 4.160     | 20.000            | 16.620    |
| 管渠   | ○1350mm<br>i=1.66‰ L=723.081m |           |           |                       |           |                       |           |           |           |           | ○1100mm<br>i=1.50‰ L=206.48m |           |           |           |           |                  |                   |           |                   |           |
| 管渠   | i=1.60‰ L=350.561m            |           |           |                       |           |                       |           |           |           |           | i=1.25‰ L=165.7m             |           |           |           |           |                  |                   |           |                   |           |
| 管渠   |                               |           |           |                       |           |                       |           |           |           |           | i=1.53‰ L=10.47m<br>推進区間     |           |           |           |           |                  |                   |           |                   |           |
| 管渠   |                               |           |           |                       |           |                       |           |           |           |           | i=1.97‰ L=114.37m            |           |           |           |           |                  |                   |           |                   |           |