

酒匂川流域下水道台帳

施設平面縦断図

(図面番号 36)

幹線名 左岸幹線

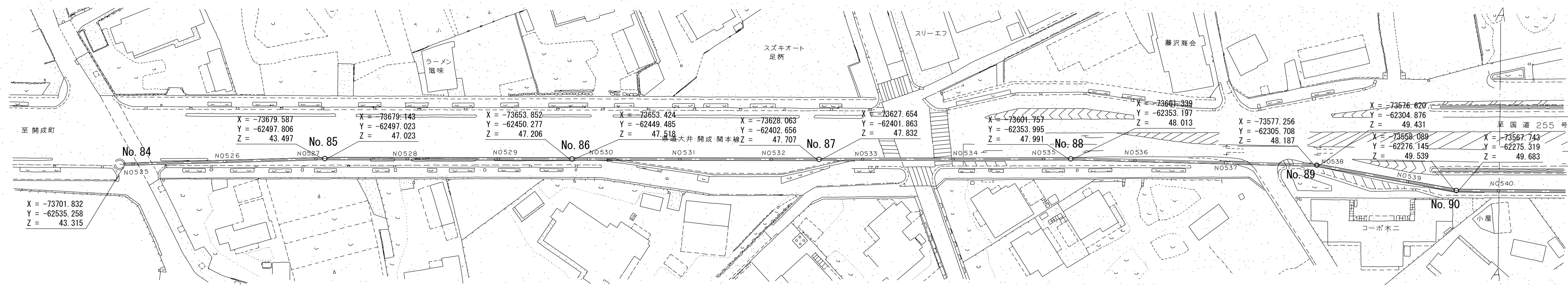

大井町金子

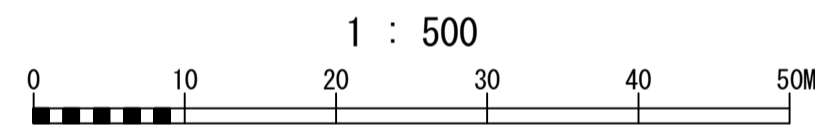

管渠構造図 S=1:30

M

N

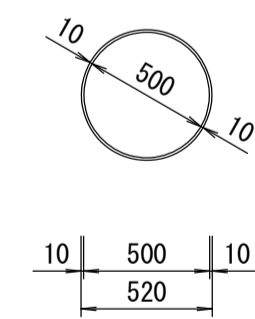

硬質塩化ビニール管

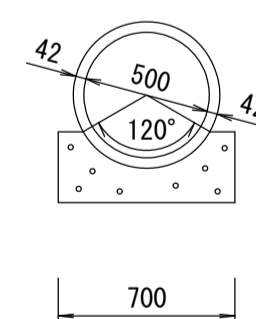

鉄筋コンクリート管
2種

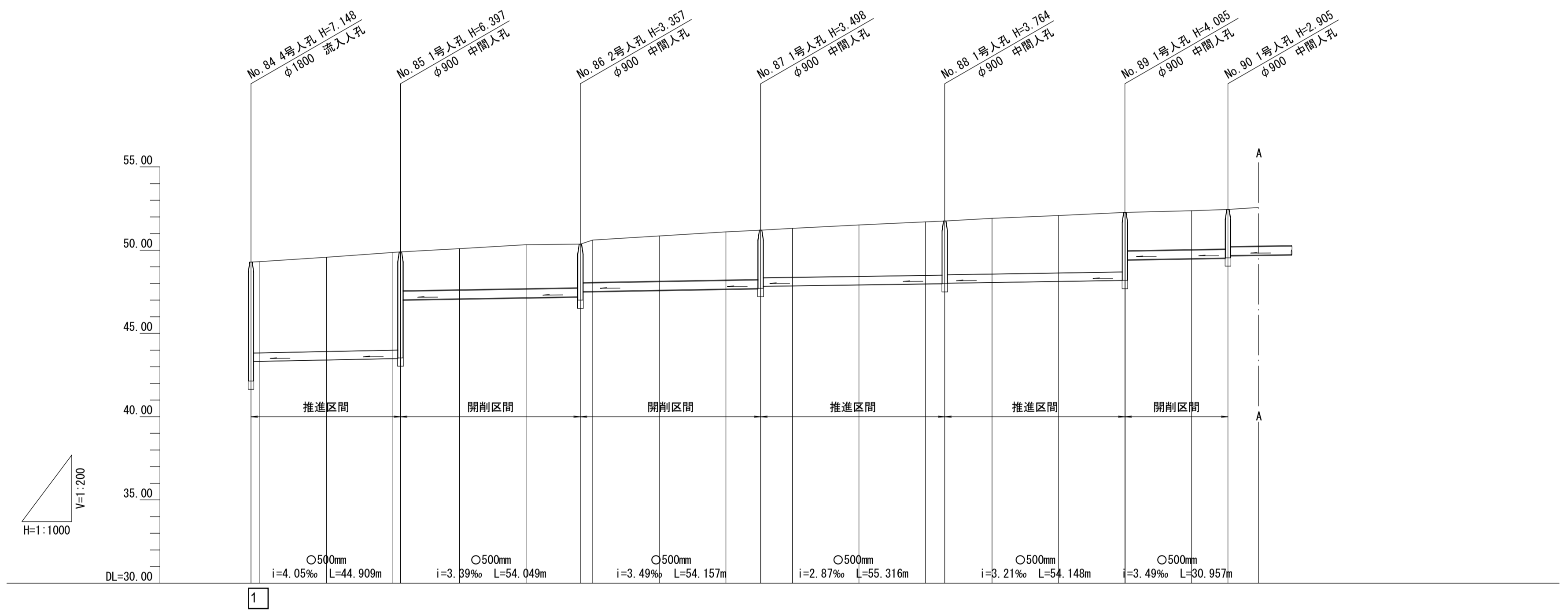

施工区	昭和63年度 第1-1工区																							
占用区間	県道大井・開成・関本線																							
管渠築造	M				N				M				N											
土被り				5.855 2.329				2.815 2.903				2.956 2.863				3.557 2.331				2.395 2.219				
地盤高	49.266	49.310	49.578	49.868	49.894	50.094	50.332	50.563	50.606	50.850	51.102	51.205	51.315	51.513	51.705	51.755	51.917	52.083	52.272	52.270	52.372	52.444	52.566	
管底高	43.315		43.497	43.497	47.023		47.206	47.206	47.518		47.707	47.832		48.013		48.187	48.187	49.431		49.539	49.683			
追加距離	0.000	1.0497.343 2.657	10650.000	10640.000	10642.262	10660.000	10680.000	10696.301	10680.000	10680.000	10640.000	10650.458	10660.000	10680.000	10700.000	10705.774	10720.000	10740.000	10758.922	10760.000	10780.000	10790.879	10800.000	
区間距離		2.657	20.000	2.252	17.748	20.000	16.301	3.699	20.000	20.000	10.458	9.542	20.000	20.000	5.774	14.226	20.000	19.822	0.078	20.000	10.879	9.121		
測点	B.P. No. 625	No. 626	No. 627 +2.252	No. 628	No. 629	+16.301 No. 630	No. 631	No. 632 +10.458	No. 633	No. 634	No. 635 +5.774	No. 636	No. 637	+19.822 No. 638	No. 639	+10.879 No. 640								

酒匂川流域下水道台帳

施設平面縦断図

(図面番号 37)

幹線名 左岸幹線

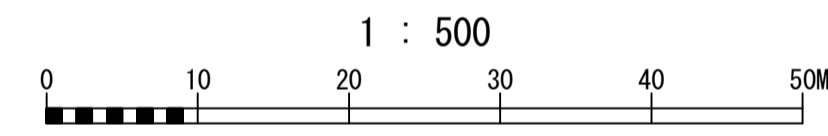
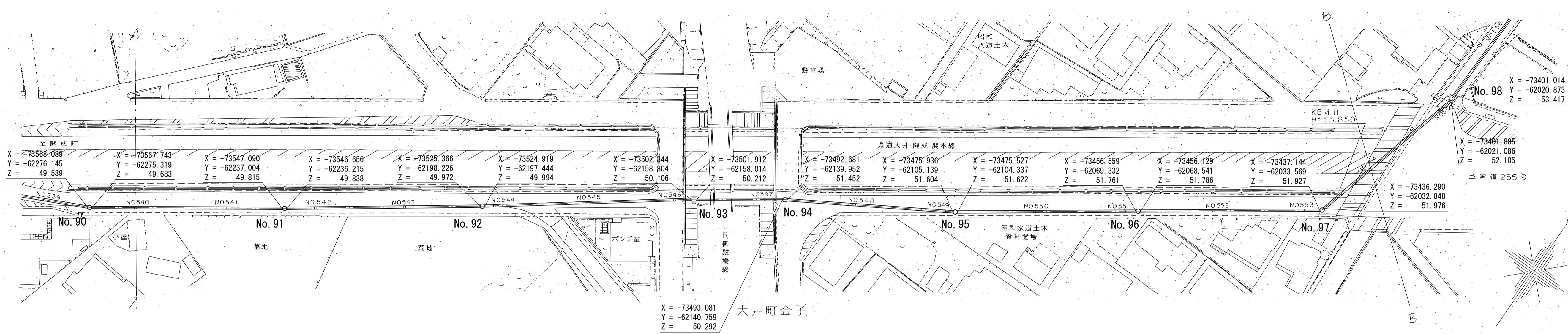

管渠構造図 S=1:30

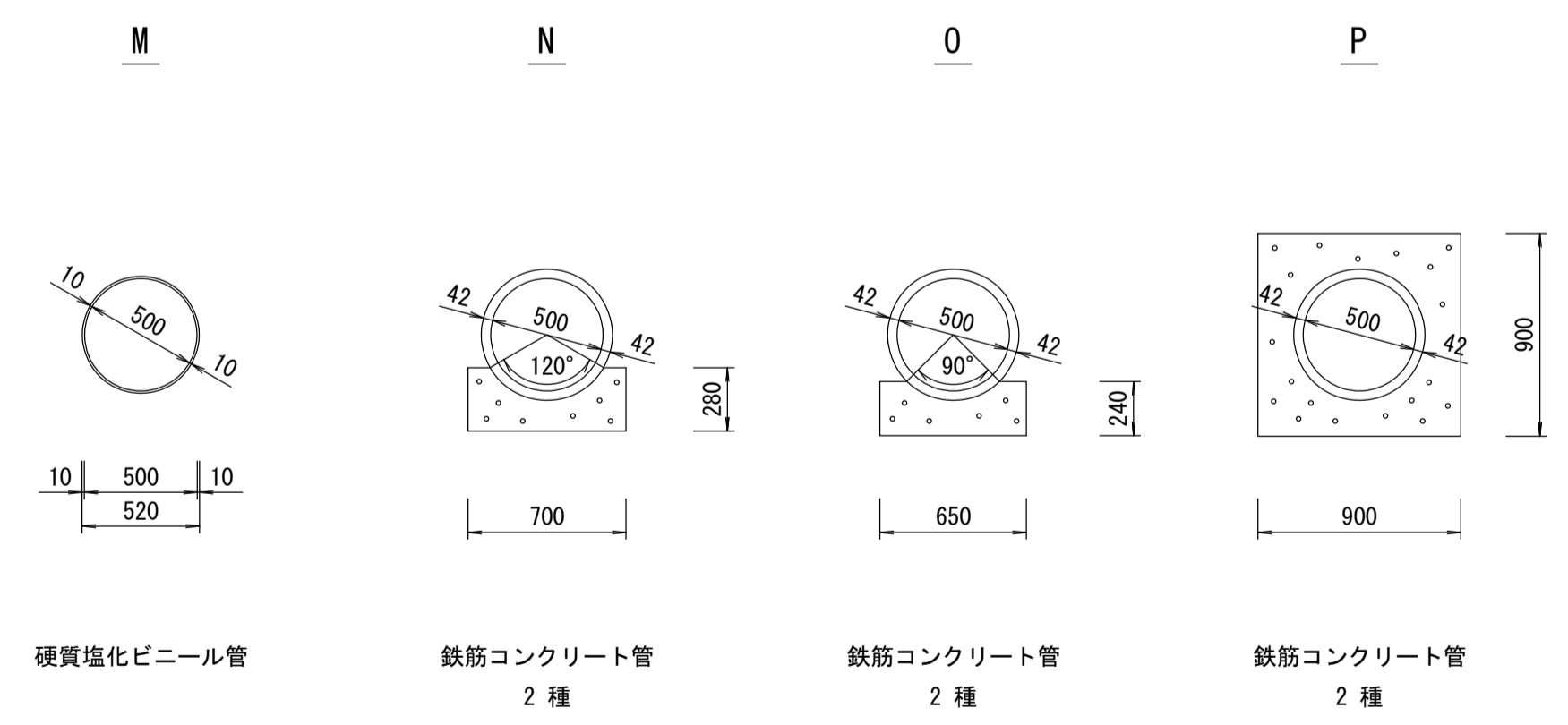
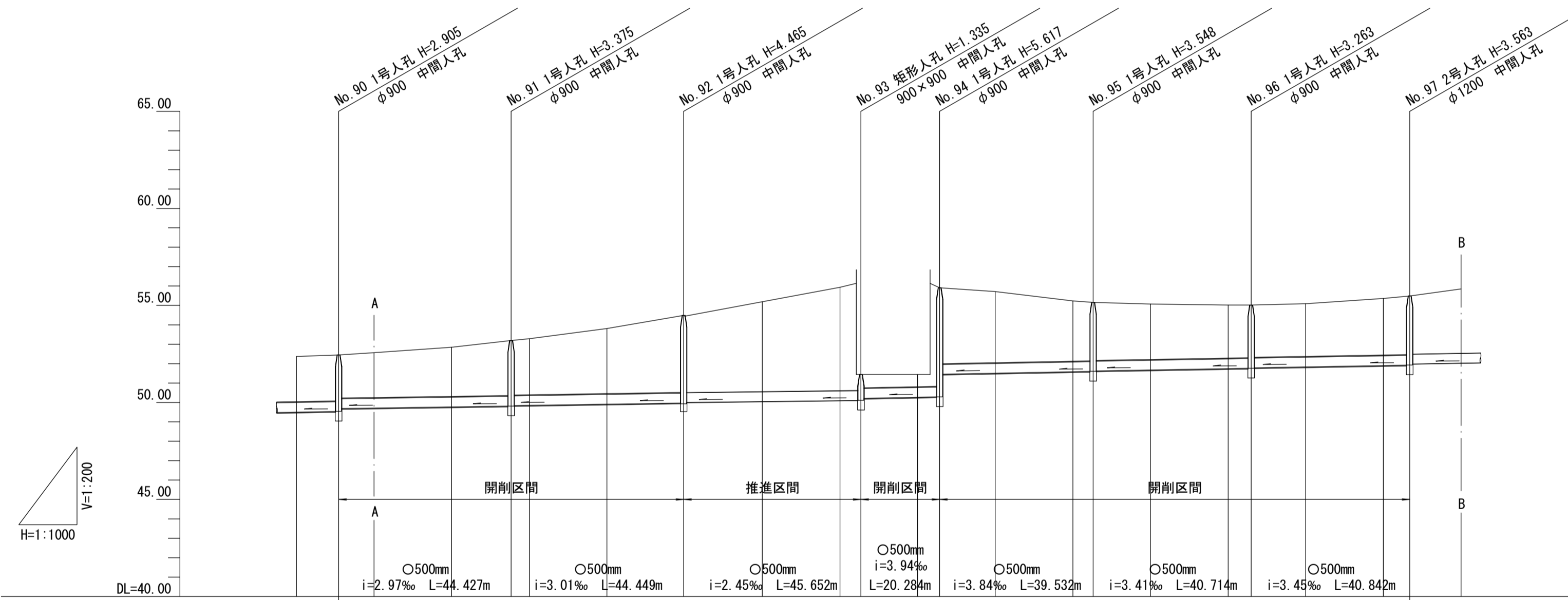

施工区	昭和63年度 第1-2工区																								
占用区間	県道大井町・開成・関本線																								
管渠築造	N			M			O			P			N												
土被り	2.363 2.219	2.833 2.810	3.933 3.933	0.825 0.687	5.075 3.915	3.006 2.988	2.721 2.696	3.022 3.005																	
地盤高	52.372	52.444	52.566	52.842	53.190 53.282	53.812	54.437 54.445	55.187	55.993 51.441	51.441 55.909	55.716	55.236 55.152	55.075	55.018 55.024	55.090	55.358 55.490	55.848								
管底高	49.539 49.683	49.815 49.838	49.872 49.994	50.106 50.212	50.292 51.452	51.604 51.622	51.761 51.786	51.927 51.976																	
追加距離	0.000	10.879 10790.879	9.121 10800.000	20.000 10820.000	15.306 10835.306	4.694 10840.000	20.000 10860.000	19.755 10879.755	0.245 10880.000	20.000 10900.000	20.000 10920.000	5.407 10925.407	14.593 10940.000	5.691 10945.691	14.305 10960.000	20.000 10980.000	5.223 10985.223	14.777 11000.000	20.000 11020.000	5.937 11025.937	14.063 11040.000	20.000 11060.000	6.779 11066.779	13.221 11080.000	
区間距離																									
測点	No. 539	+10.879 No. 540	No. 541	+15.306 No. 542	No. 543	+19.755 No. 544	No. 545	No. 546	+5.407 No. 547	+5.691 No. 548	No. 549	+5.223 No. 550	No. 551	+5.937 No. 552	No. 553	+6.779 No. 554	No. 555								

酒匂川流域下水道台帳

施設平面縦断図

(図面番号 38)

幹線名 左岸幹線

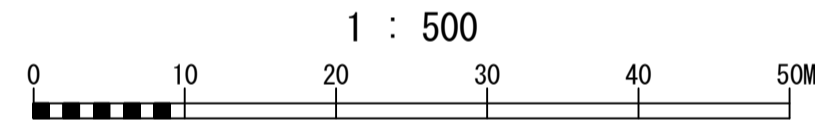
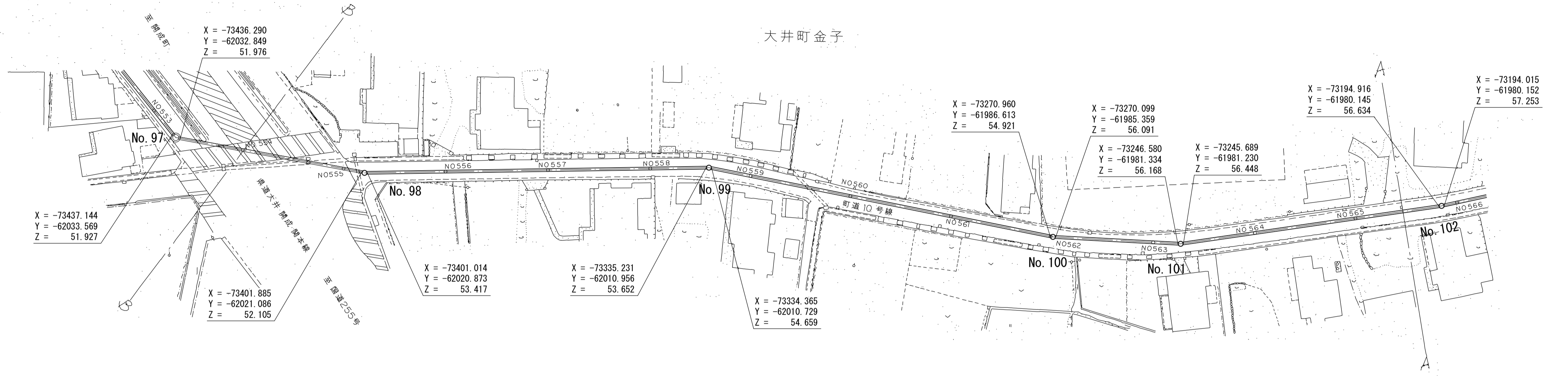

管渠構造図 S=1:30

M N

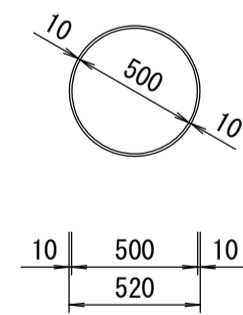

硬質塩化ビニール管

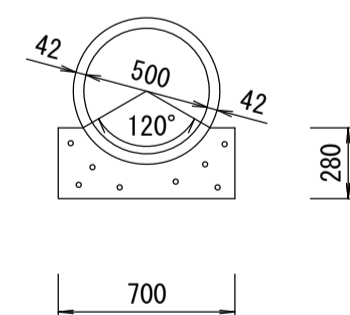

鉄筋コンクリート管
2種

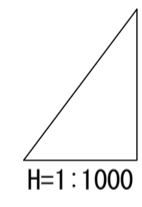
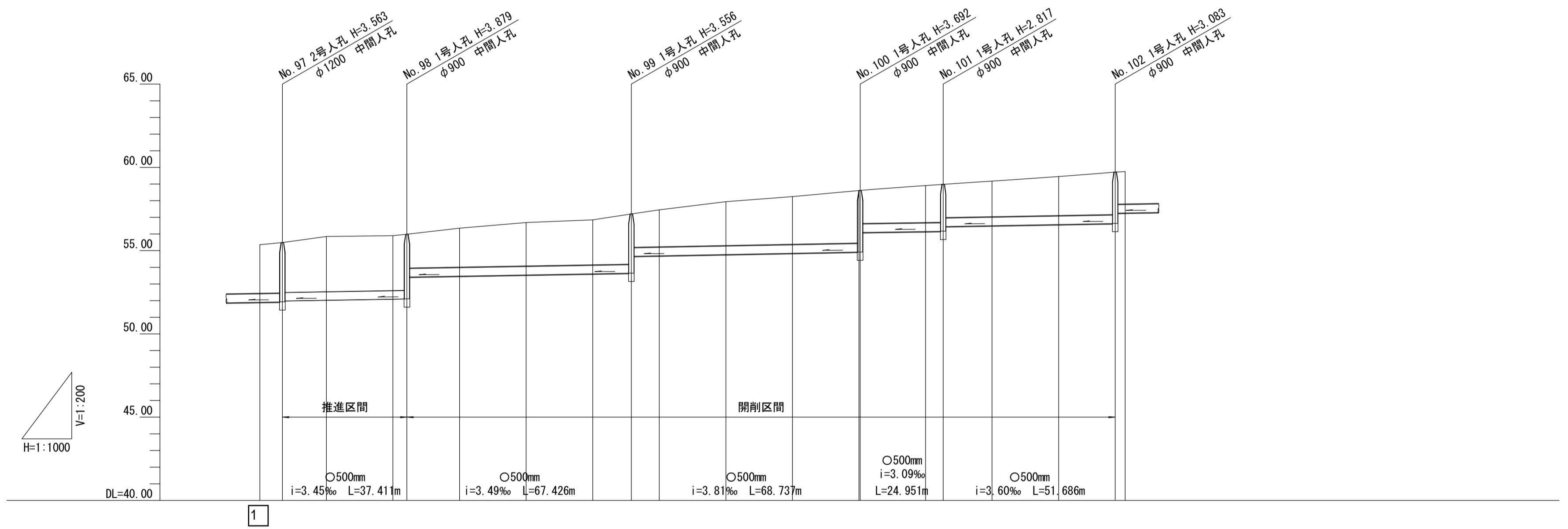

施工工区	昭和63年度 第1-3工区																																									
占用区間	大井町 町道10号線																																									
管渠築造	M							N																																		
土被り	3,063	2,972	3,337	2,205	3,014	2,007	3,150	1,980	2,275	1,995	2,541	1,922	2,541	1,922																												
地盤高	55.358	55.490	55.900	55.984	56.346	56.663	56.951	57.208	57.448	57.944	58.244	58.609	58.613	58.915	58.985	59.173	59.455	59.717	59.749																							
管底高	51.927	51.976	52.105	53.417	53.652	54.659	54.921	56.091	56.168	56.448	56.634	57.253	57.253	57.253	57.253	57.253	57.253	57.253	57.253																							
追加距離	0.000	11060.000	6.775	11066.775	11080.000	20.000	11100.000	4.186	11104.186	11120.000	15.814	11120.000	20.000	11140.000	20.000	11160.000	11.612	11171.612	8.388	11180.000	20.000	11200.000	20.000	11220.000	20.000	11240.000	0.349	11240.349	19.651	11260.000	5.300	11265.300	14.700	11280.000	20.000	11300.000	16.986	11316.986	3.014	11320.000		
区間距離	0.000	6.775	13.225	20.000	4.186	15.814	20.000	11.612	8.388	20.000	20.000	20.000	20.000	20.000	19.651	5.300	14.700	20.000	16.986	3.014																						
測点	No. 553	+6.775	No. 554	No. 555	+4.186	No. 556	No. 557	No. 558	+11.612	No. 559	No. 560	No. 561	No. 562	+0.349	No. 563	+5.300	No. 564	No. 565	+16.986	No. 566																						

調整
年月
平成
2
年
3
月
ページ

酒匂川流域下水道台帳

施設平面縦断図

(図面番号 39)

幹線名 左岸幹線

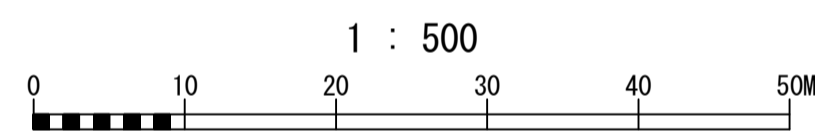
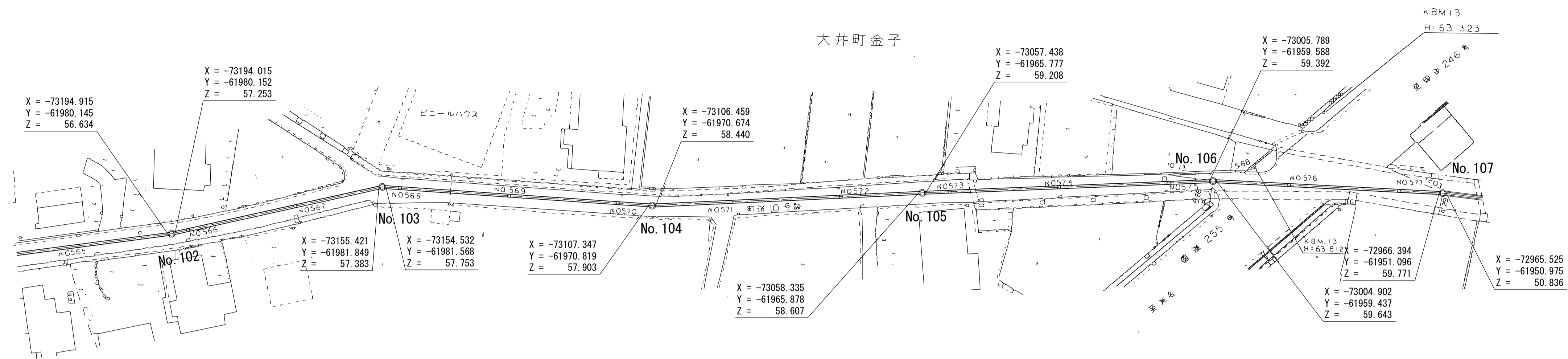

管渠構造図 S=1:30

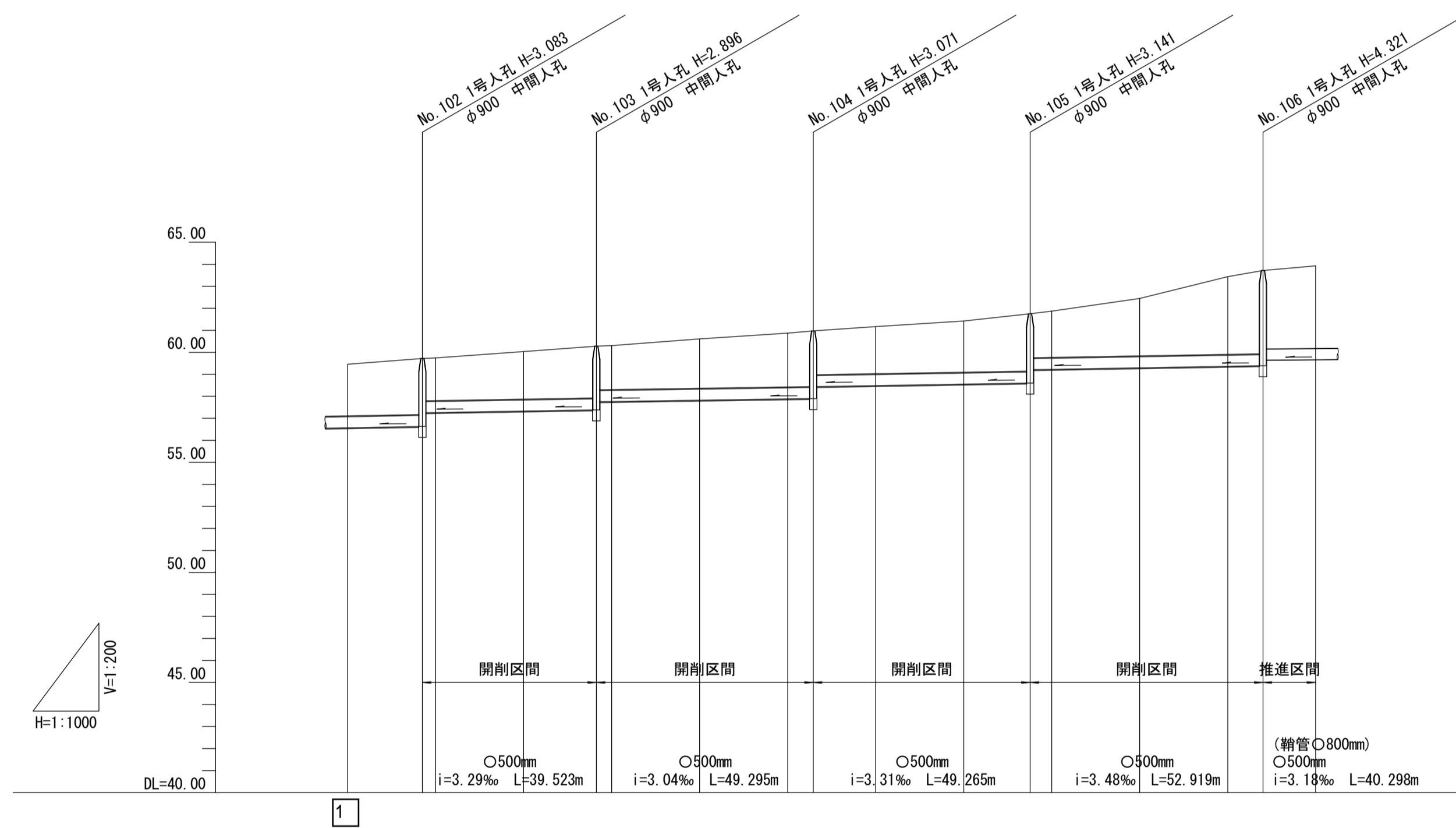
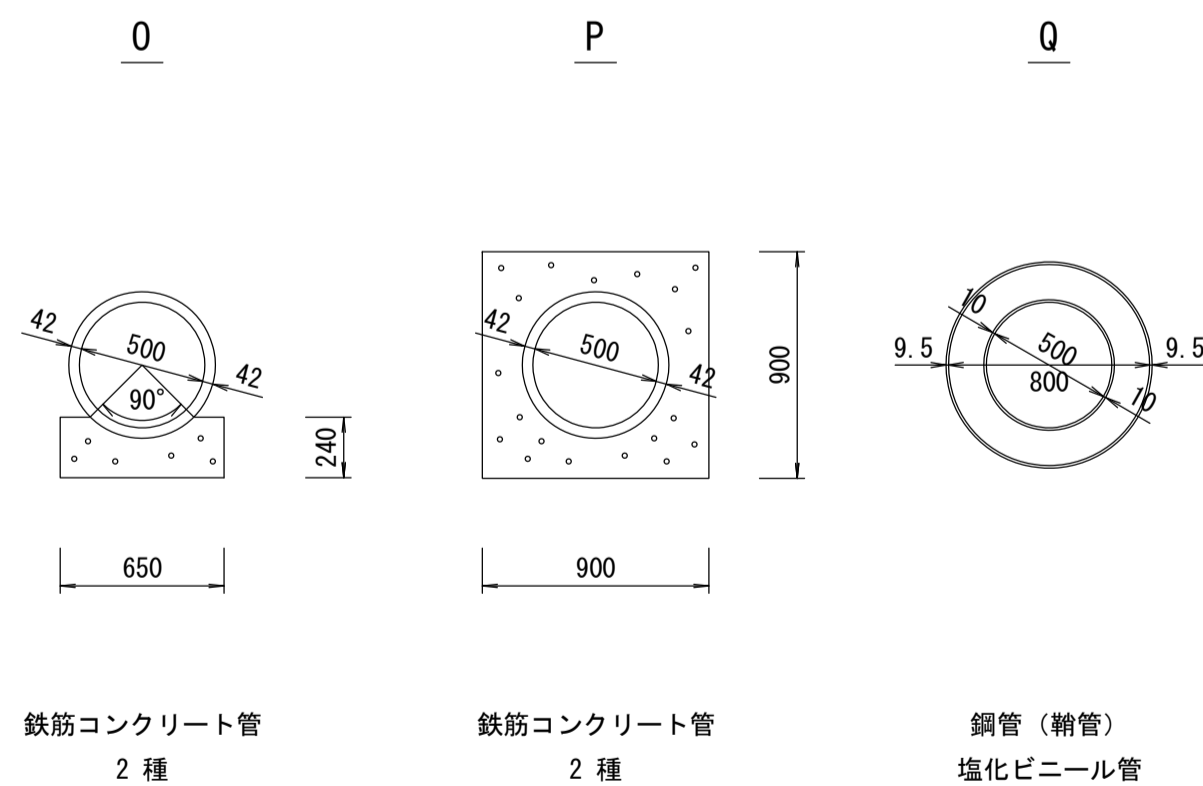

測点	昭和63年度 第1-4工区										平成元年度 第1-5工区			
	No. 565	+16.986 No. 566	No. 567	+16.509 No. 568	No. 569	No. 570	+5.804 No. 571	No. 572	+15.069 No. 573	No. 574	No. 575	+7.888 No. 576	No. 577	
施工区	大井町 町道10号線												国道 255号線	
占用区間	O												P	Q
管渠築造	O												P	Q
土被り	2,541 1,922	2,354 1,984	2,529 1,992	2,599 1,988	3,779 3,410									
地盤高	59.455	59.717 59.749	60.029	60.279 60.301	60.605	60.873 60.974	61.166	61.422	61.748 61.872	62.449	63.439	63.713	63.927	
管底高	56.634 57.253	57.383 57.753	57.903 58.440	58.607 59.208	59.392 59.643									
追加距離	0.000	16.986 3.014	20.000	16.509 3.491	20.000	20.000 5.804	14.196	20.000	15.069 4.931	20.000	20.000	7.888	12.012	
区間距離														

酒匂川流域下水道台帳

施設平面縦断図

(図面番号 40)

幹線名 左岸幹線

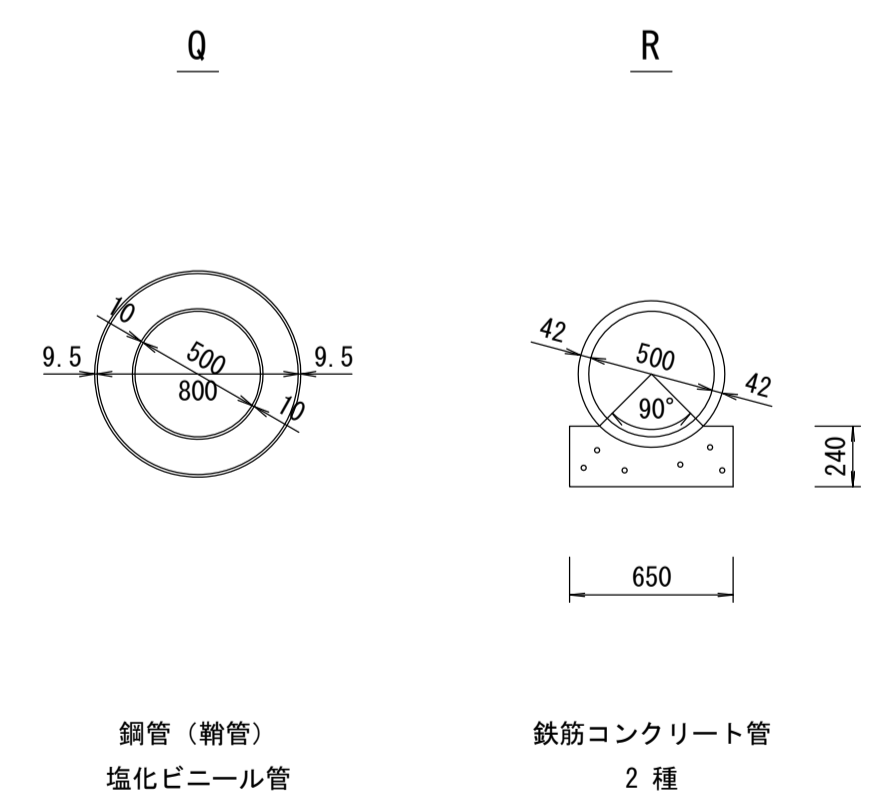
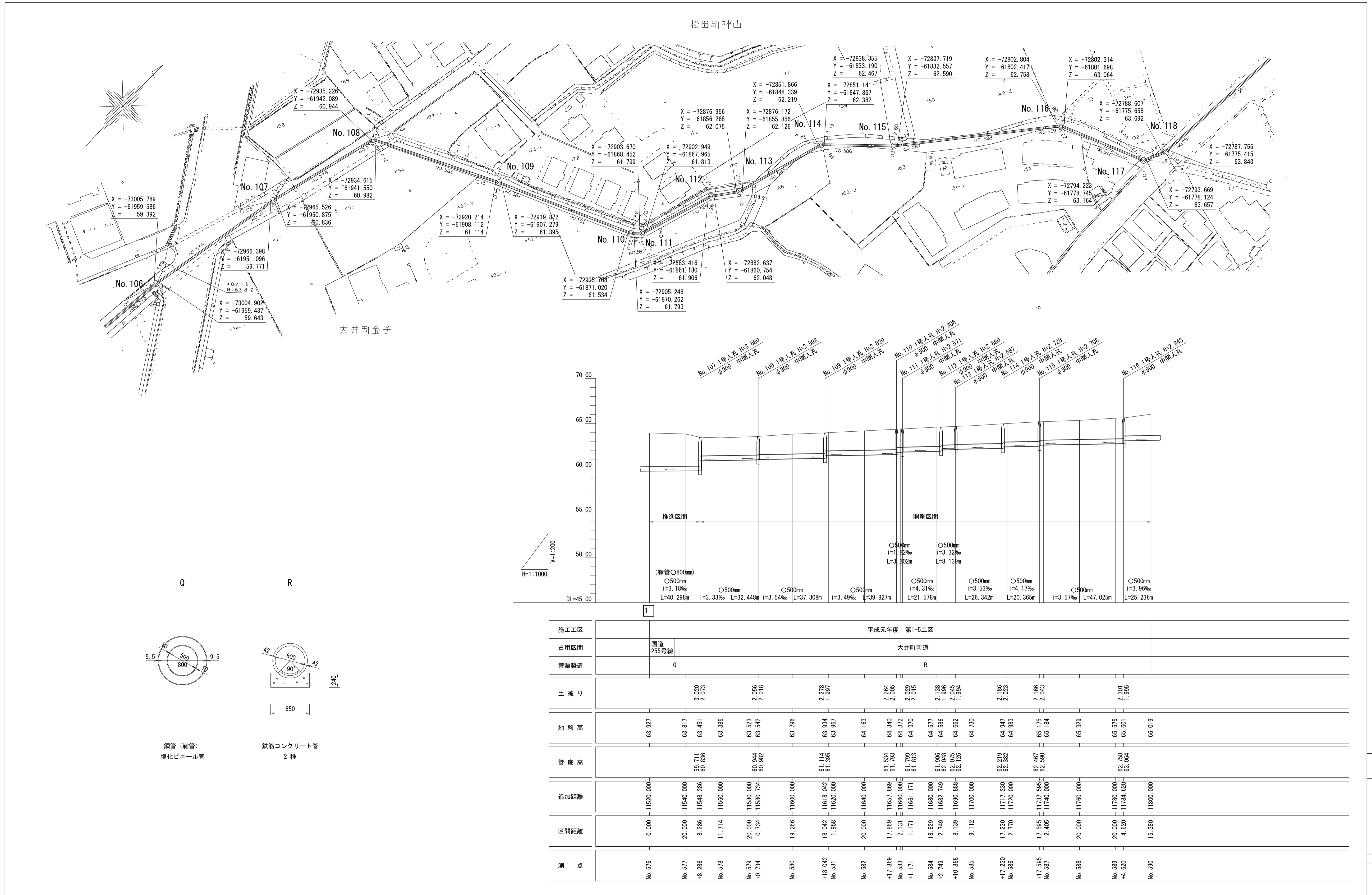

測点	平成元年度 第1-5工区															
	Q								R							
No. 576	0.000	11520.000	63.927	59.711	61.534	61.534	61.534	61.534	61.534	61.534	61.534	61.534	61.534	61.534	61.534	61.534
No. 577	20.000	11540.000	63.817	60.836	61.793	61.793	61.793	61.793	61.793	61.793	61.793	61.793	61.793	61.793	61.793	61.793
+8.286	8.286	11548.286	63.451	60.944	61.813	61.813	61.813	61.813	61.813	61.813	61.813	61.813	61.813	61.813	61.813	61.813
No. 578	11.714	11560.000	63.386	60.982	61.813	61.813	61.813	61.813	61.813	61.813	61.813	61.813	61.813	61.813	61.813	61.813
No. 579	20.000	11580.000	63.523	61.114	61.799	61.799	61.799	61.799	61.799	61.799	61.799	61.799	61.799	61.799	61.799	61.799
+0.734	0.734	11580.734	63.542	61.395	61.813	61.813	61.813	61.813	61.813	61.813	61.813	61.813	61.813	61.813	61.813	61.813
No. 580	19.266	11600.000	63.796	61.114	61.799	61.799	61.799	61.799	61.799	61.799	61.799	61.799	61.799	61.799	61.799	61.799
+18.042	18.042	11618.042	63.934	61.534	61.793	61.793	61.793	61.793	61.793	61.793	61.793	61.793	61.793	61.793	61.793	61.793
No. 581	1.958	11620.000	63.967	61.395	61.813	61.813	61.813	61.813	61.813	61.813	61.813	61.813	61.813	61.813	61.813	61.813
No. 582	20.000	11640.000	64.163	61.114	61.799	61.799	61.799	61.799	61.799	61.799	61.799	61.799	61.799	61.799	61.799	61.799
+17.869	17.869	11657.869	64.340	61.534	61.793	61.793	61.793	61.793	61.793	61.793	61.793	61.793	61.793	61.793	61.793	61.793
No. 583	2.131	11660.000	64.372	61.395	61.813	61.813	61.813	61.813	61.813	61.813	61.813	61.813	61.813	61.813	61.813	61.813
+1.171	1.171	11661.171	64.370	61.799	61.813	61.813	61.813	61.813	61.813	61.813	61.813	61.813	61.813	61.813	61.813	61.813
No. 584	18.829	11680.000	64.577	61.096	61.813	61.813	61.813	61.813	61.813	61.813	61.813	61.813	61.813	61.813	61.813	61.813
+2.749	2.749	11682.749	64.586	62.048	62.048	62.048	62.048	62.048	62.048	62.048	62.048	62.048	62.048	62.048	62.048	62.048
+10.888	10.888	11690.888	64.662	62.075	62.126	62.126	62.126	62.126	62.126	62.126	62.126	62.126	62.126	62.126	62.126	62.126
No. 585	9.112	11700.000	64.730	62.467	62.590	62.590	62.590	62.590	62.590	62.590	62.590	62.590	62.590	62.590	62.590	62.590
+17.230	17.230	11717.230	64.947	62.219	62.382	62.382	62.382	62.382	62.382	62.382	62.382	62.382	62.382	62.382	62.382	62.382
No. 586	2.770	11720.000	64.983	62.467	62.590	62.590	62.590	62.590	62.590	62.590	62.590	62.590	62.590	62.590	62.590	62.590
+17.595	17.595	11737.595	65.175	62.467	62.590	62.590	62.590	62.590	62.590	62.590	62.590	62.590	62.590	62.590	62.590	62.590
No. 587	2.405	11740.000	65.184	62.467	62.590	62.590	62.590	62.590	62.590	62.590	62.590	62.590	62.590	62.590	62.590	62.590
No. 588	20.000	11760.000	65.329	62.467	62.590	62.590	62.590	62.590	62.590	62.590	62.590	62.590	62.590	62.590	62.590	62.590
No. 589	20.000	11780.000	65.575	62.467	62.590	62.590	62.590	62.590	62.590	62.590	62.590	62.590	62.590	62.590	62.590	62.590
+4.620	4.620	11784.620	65.601	62.467	62.590	62.590	62.590	62.590	62.590	62.590	62.590	62.590	62.590	62.590	62.590	62.590
No. 590	15.380	11800.000	66.019	62.467	62.590	62.590	62.590	62.590	62.590	62.590	62.590	62.590	62.590	62.590	62.590	62.590

酒匂川流域下水道台帳

施設平面縦断図

(図面番号 41)

幹線名 左岸幹線

松田町神山

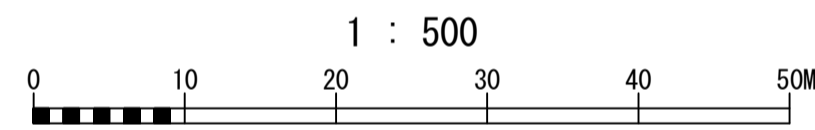
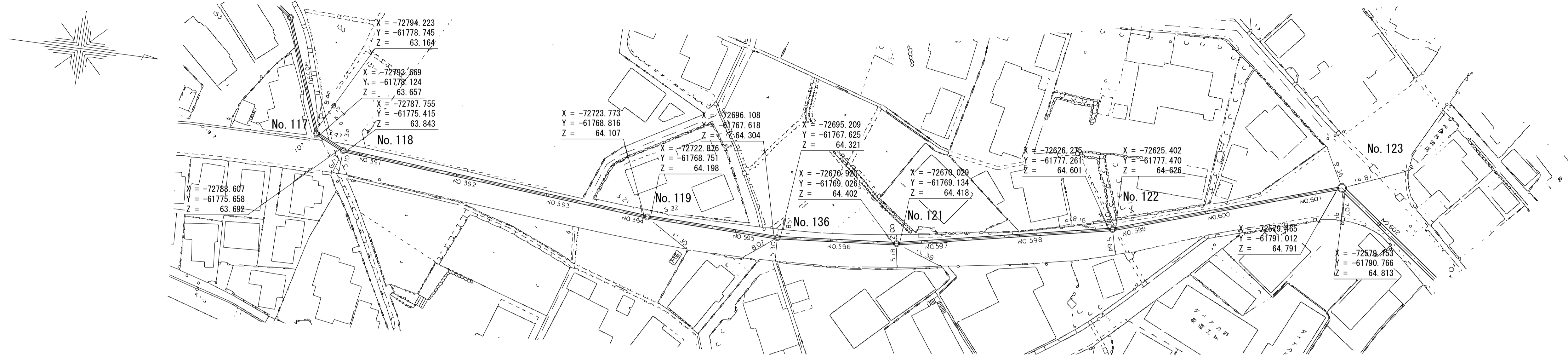

管渠構造図 S=1:30

Q R S

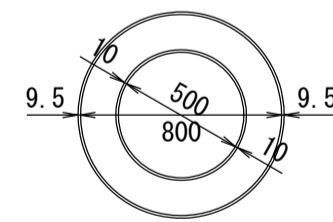

鋼管(鋼管)
塩化ビニール管

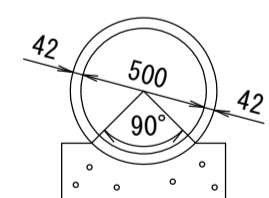

鉄筋コンクリート管
2種

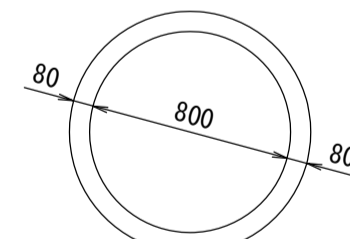

推進用鉄筋コンクリート管

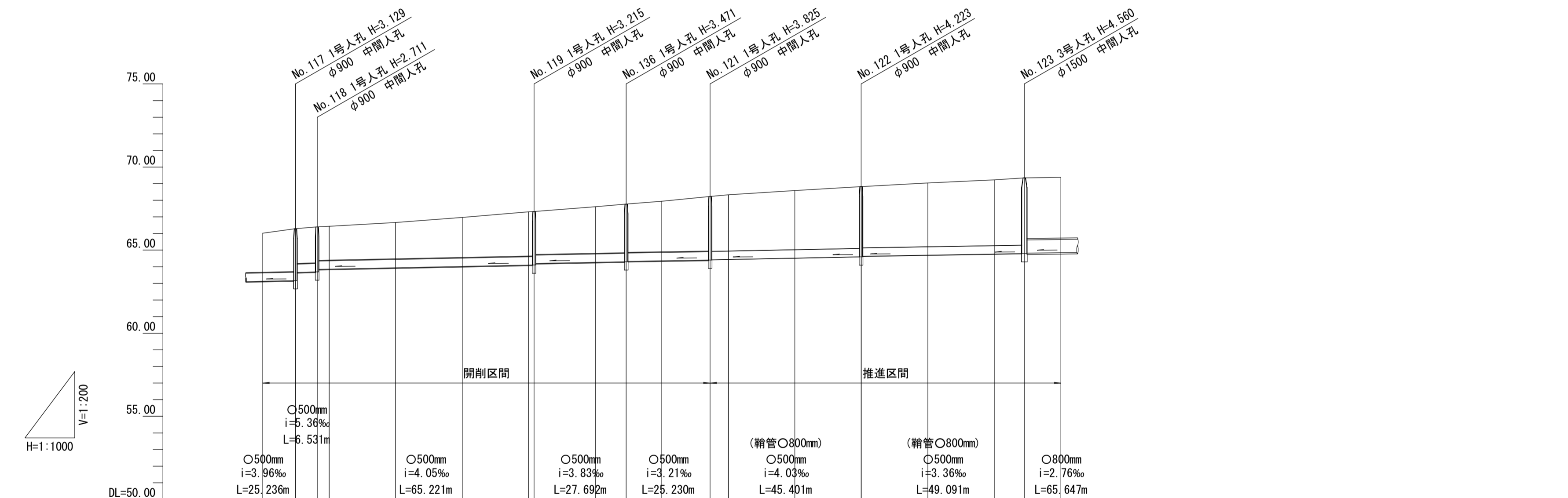

施工区	平成元年度 第1-5工区		平成元年度 第1-6工区				平成元年度 第1-7工区		
占用区間	大井町町道		主要地方道松田・国府津線				県道松田羽根尾線		
管渠築造	R		Q				S		
土被り	2.587 2.084 2.169 2.018	2.673 2.582	2.929 2.912	3.283 3.149	3.563 3.538	3.900 3.658			
地盤高	66.019 66.283 66.403 66.451	66.667 66.971	67.310 67.322	67.608 67.775 67.942	68.227 68.330	68.586 68.824 68.824	69.042 69.227	69.351 69.378	
管底高	63.164 63.657 63.692 63.843	64.107 64.198	64.304 64.321	64.402 64.418	64.601 64.626	64.791 64.813			
追加距離	0.000 9.856 6.531 3.613	11800.000 11809.856 11816.387 11820.000	20.000 1.608	18.392 9.300 10.700	11900.000 11909.300 11920.000	11934.530 11940.000	11960.000 11979.831 11980.000	12000.000 12020.000 12029.022	12040.000 12040.000
区間距離									
測点	No. 590 +9.856 +16.387 No. 591	No. 592 No. 593	No. 594 +1.608 No. 595 +9.300 No. 596	+4.530 No. 597	No. 598 +19.931 No. 599	No. 600 No. 601 +9.022 No. 602			

酒匂川流域下水道台帳

施設平面縦断図

(図面番号 42)

幹線名 左岸幹線

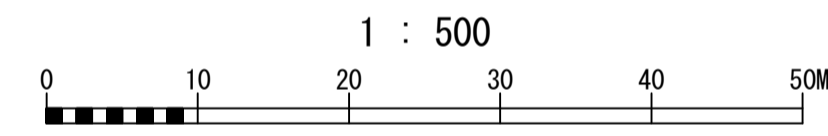
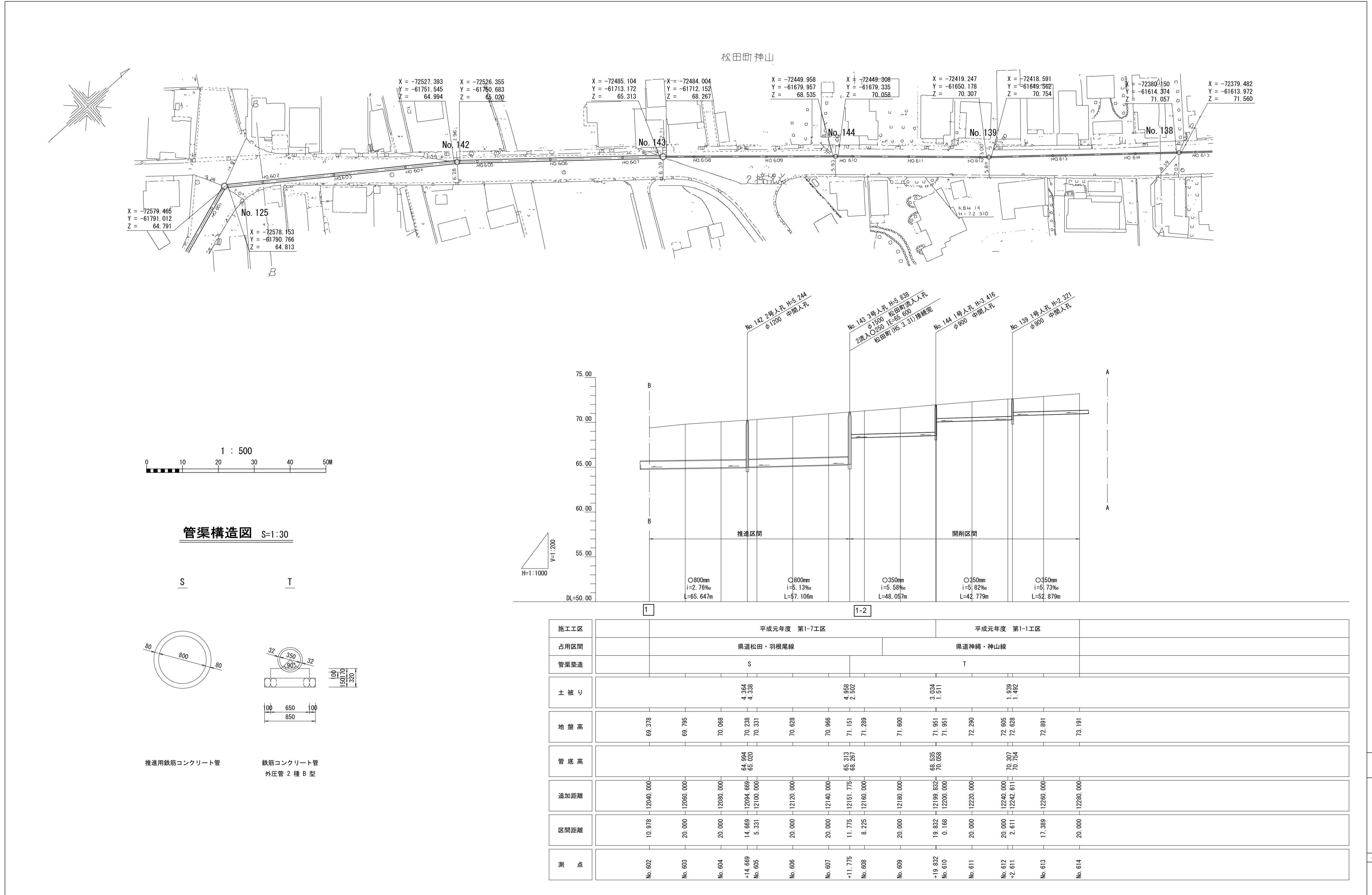

管渠構造図 S=1:30

S T

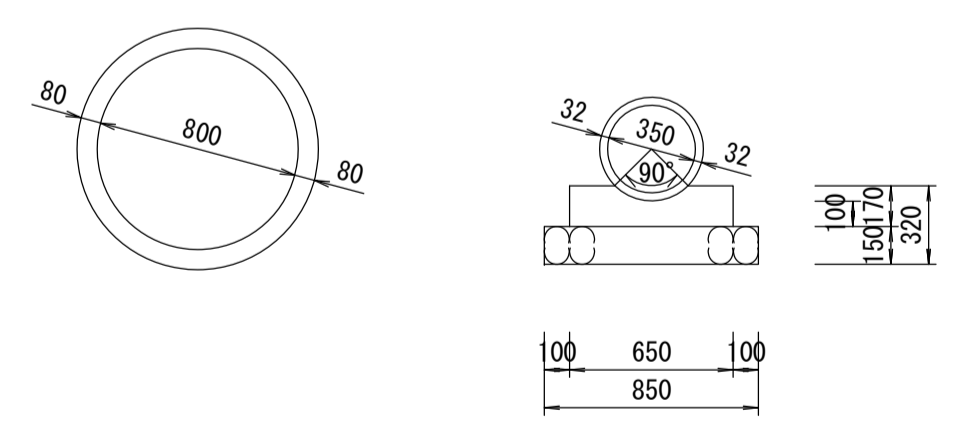

推進用鉄筋コンクリート管
鉄筋コンクリート管
外圧管 2種 B型

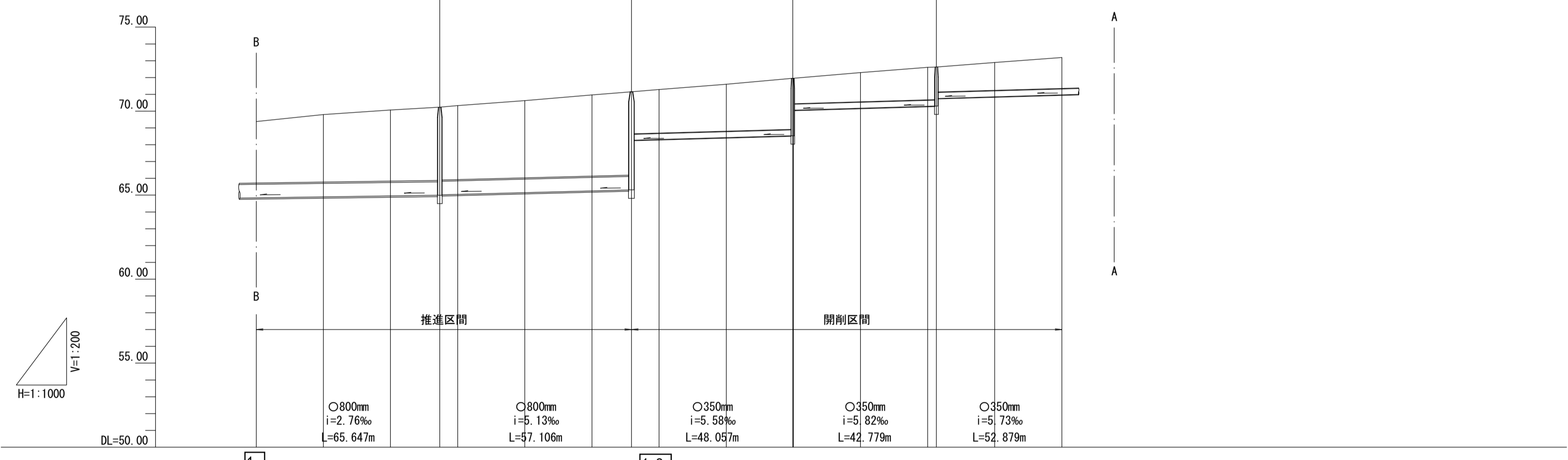

施工区	平成元年度 第1-7工区										平成元年度 第1-1工区						
	県道松田・羽根尾線					県道神縄・神山線											
占用区間	S										T						
管渠築造	S										T						
土被り	4.384 4.338					4.958 2.502					3.034 1.511		1.939 1.492				
地盤高	69.378	69.795	70.068	70.238	70.331	70.628	70.966	71.151	71.289	71.600	71.951	71.951	72.290	72.605	72.628	72.891	73.191
管底高			64.894 65.020				65.313 68.267			68.535 70.058		70.307 70.754					
追加距離		12040.000	12060.000	12080.000	12094.669 12100.000	12120.000	12140.000	12151.775 12160.000	12180.000	12198.832 12200.000	12220.000	12240.000 12242.611	12260.000	12280.000	12280.000		
区間距離	10.978	20.000	20.000	14.669 5.331	20.000	20.000	11.775 8.225	20.000	19.832 0.168	20.000	20.000	2.611	17.389	20.000			
測点	No. 602	No. 603	No. 604	+1.669 No. 605	No. 606	No. 607	+1.775 No. 608	No. 609	+19.832 No. 610	No. 611	No. 612 +2.611	No. 613	No. 614				